

541 3ph

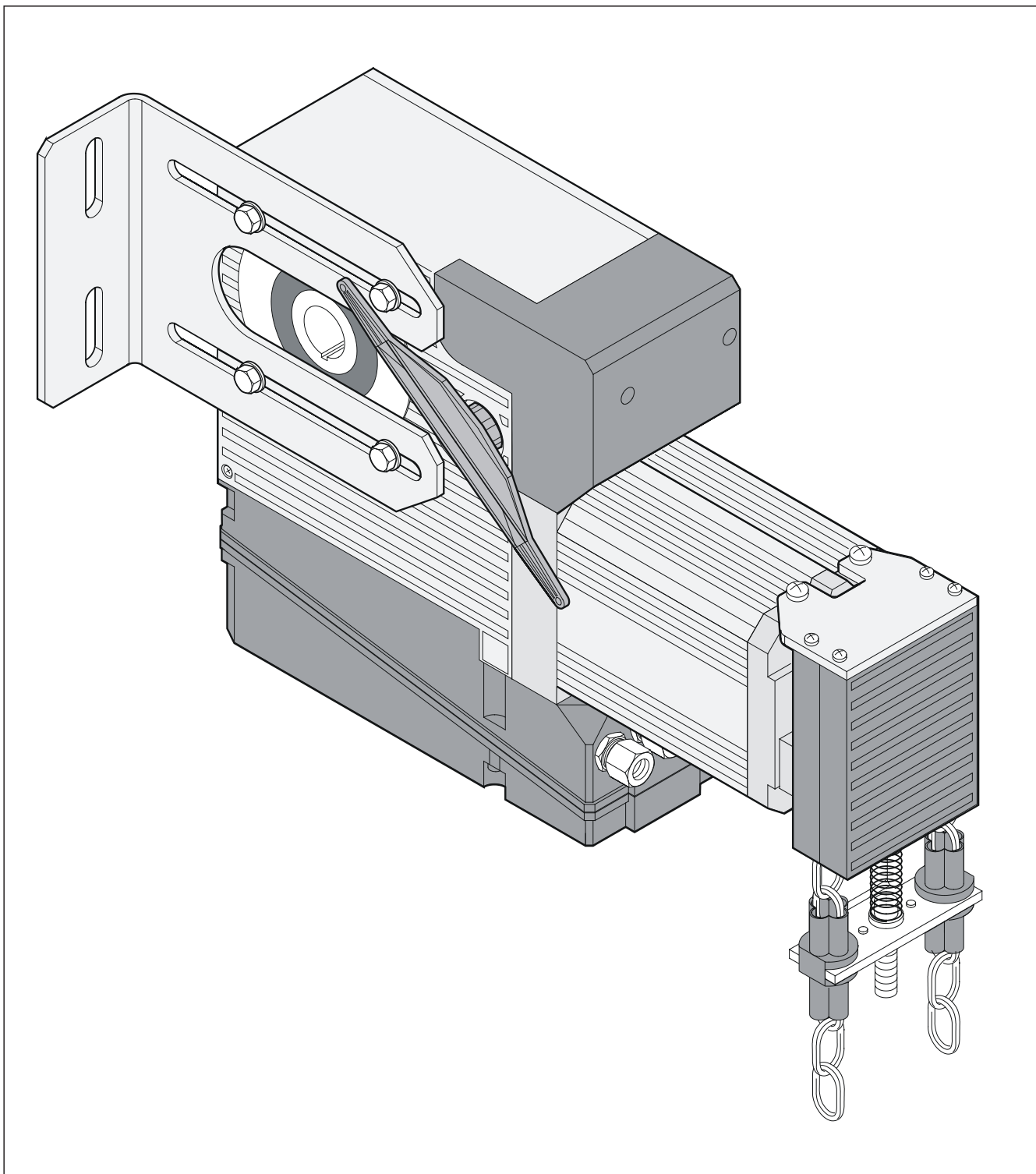

FAAC

CE DECLARATION OF MACHINE CONFORMITY (DIRECTIVE 2006/42/EC)

Manufacturer : FAAC S.p.A.

Address: Via Calari, 10 - 40069 Zola Predosa BOLOGNA - ITALY

Declares that: Operator mod. **541 3ph**

- is built to be incorporated into a machine or to be assembled with other machinery to create a machine under the provisions of Directive 2006/42/EC;
- conforms to the essential safety requirements of the other following EEC directives:

2006/95/EC Low Voltage directive.

2004/108/EC Electromagnetic Compatibility directive

and also declares that it is prohibited to put into service the machinery until the machine in which it will be integrated or of which it will become a component has been identified and declared as conforming to the conditions of Directive 2006/42/EC.

Bologna, 01 January 2011

The Managing Director

A. Marcellan



WARNINGS FOR THE INSTALLER GENERAL SAFETY OBLIGATIONS

- 1) **ATTENTION! To ensure the safety of people, it is important that you read all the following instructions. Incorrect installation or incorrect use of the product could cause serious harm to people.**
- 2) Carefully read the instructions before beginning to install the product.
- 3) Do not leave packing materials (plastic, polystyrene, etc.) within reach of children as such materials are potential sources of danger.
- 4) Store these instructions for future reference.
- 5) This product was designed and built strictly for the use indicated in this documentation. Any other use, not expressly indicated here, could compromise the good condition/operation of the product and/or be a source of danger.
- 6) FAAC declines all liability caused by improper use or use other than that for which the automated system was intended.
- 7) Do not install the equipment in an explosive atmosphere: the presence of inflammable gas or fumes is a serious danger to safety.
- 8) The mechanical parts must conform to the provisions of Standards EN 12604 and EN 12605.
For non-EU countries, to obtain an adequate level of safety, the Standards mentioned above must be observed, in addition to national legal regulations.
- 9) FAAC is not responsible for failure to observe Good Technique in the construction of the closing elements to be motorised, or for any deformation that may occur during use.
- 10) The installation must conform to Standards EN 12453 and EN 12445.
For non-EU countries, to obtain an adequate level of safety, the Standards mentioned above must be observed, in addition to national legal regulations.
- 11) Before attempting any job on the system, cut out electrical power.
- 12) The mains power supply of the automated system must be fitted with an all-pole switch with contact opening distance of 3mm or greater. Use of a 6A thermal breaker with all-pole circuit break is recommended.
- 13) Make sure that a differential switch with threshold of 0.03 A is installed upstream of the system.
- 14) Make sure that the earthing system is perfectly constructed, and connect metal parts of the means of the closure to it.
- 15) The safety devices (EN 12978 standard) protect any danger against **mechanical movement Risks**, such as crushing, dragging, shearing.
- 16) Use of at least one indicator-light (e.g. FAACLIGHT) is recommended for every system, as well as a warning sign adequately secured to the frame structure, in addition to the devices mentioned at point 15).
- 17) FAAC declines all liability as concerns safety and efficient operation of the automated system, if system components not produced by FAAC are used.
- 18) For maintenance, strictly use original parts by FAAC.
- 19) Do not in any way modify the components of the automated system.
- 20) The installer shall supply all information concerning manual operation of the system in case of an emergency, and shall hand over to the user the warnings handbook supplied with the product.
- 21) Do not allow children or adults to stay near the product while it is operating.
- 22) Keep remote controls or other pulse generators away from children to prevent the automated system from being activated involuntarily.
- 23) Transit under the door is permitted only when the automated system is stopped.
- 24) The user must not attempt any kind of repair or direct action without and contact qualified personnel only.
- 25) Maintenance: check at least every 6 months the efficiency of the system, particularly the efficiency of the safety devices (including, where applicable, the operator thrust force) and of the release devices.
- 26) **Anything not expressly specified in these instructions is not permitted.**

AUTOMATED SYSTEM 541 3ph

These instructions apply to the following models:

FAAC 541 3ph

The 541 3ph automated system is designed for automating balanced industrial sectional doors.

They consist of an electro-mechanical operator, with on-board (541D) inter-connection board, for remote control unit (844T). Installation is possible either directly on the shaft of the rope-winding drums, or by chain transmission (optional item) with a reduction ratio of 1:1.5 or 1:2.

The non-reversing system ensures mechanical locking of the door when the motor is not operating and, therefore, no lock needs to be installed; the manual release and the manual opening system (in models for which it is supplied) make it possible to move the door in case of a power cut or malfunction.

The 541 3ph automated systems was designed and built for indoor and outdoor use.

Table 1

Type of application	Rated torque (Nm)	Rope shaft speed (rpm)	Rope max
Direct	70	23	24
Reduction ratio 1:1.5	105	17,2	18
Reduction ratio 1:2	140	11,5	12

Graph 1 shows with which type of application the 541 3ph can be installed, considering the maximum force required to move the door **F**, in daN (1daN = force required to lift 1 kg) and the diameter of the rope-winding drum **Dt** in millimeters. For example, if a door can be moved with a force of 108 daN and the drum diameter is 180 mm, a 541 3ph with chain transmission 1:1.5 must be installed.

N.B. Force **F** can be measured with a dynamometer. It is not related to the weight of the door, but to its balance.

1. TECHNICAL SPECIFICATIONS

Power supply (Vac 50-60Hz)	400 (+6 -10%)
Electric motor	3 - phase induction 1450rpm
Maximum absorbed power (W)	720
Absorbed current (A)	1,1
Starting capacitor (µF)	20
Winding thermal protection (°C)	140
Use frequency (S3) ROT	60%
Max number consecutive cycles	6
Power take-off	Hollow through shaft diam. 25,4mm (1")
Power take-off rotation speed (rpm)	23
Rated torque of power take-off (Nm)	70
Power take-off max revs	24
Protection class	IP54
Operating ambient temperature (°C)	-20 / +55
Gearmotor max weight (Kg)	14
Type of oil	FAAC XD220
Oil quantity (l)	0,9
Note: consult Table 1 for chain transmission applications	

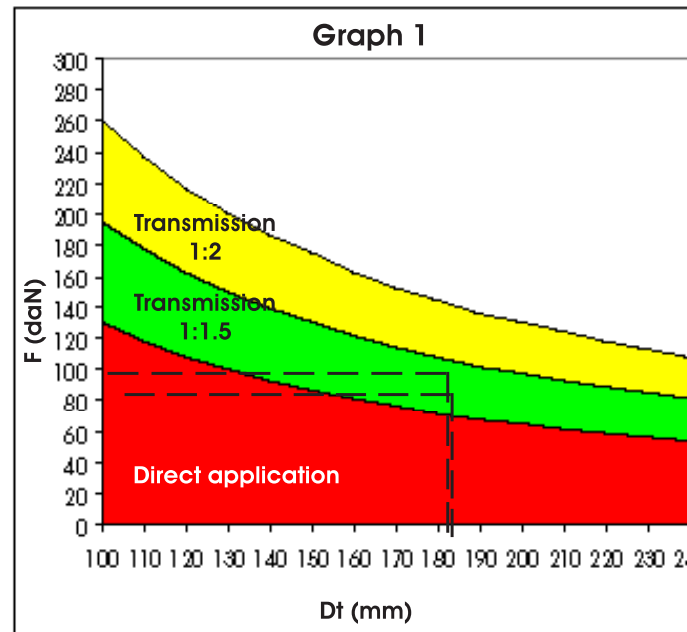

2. DIMENSIONS AND DESCRIPTION

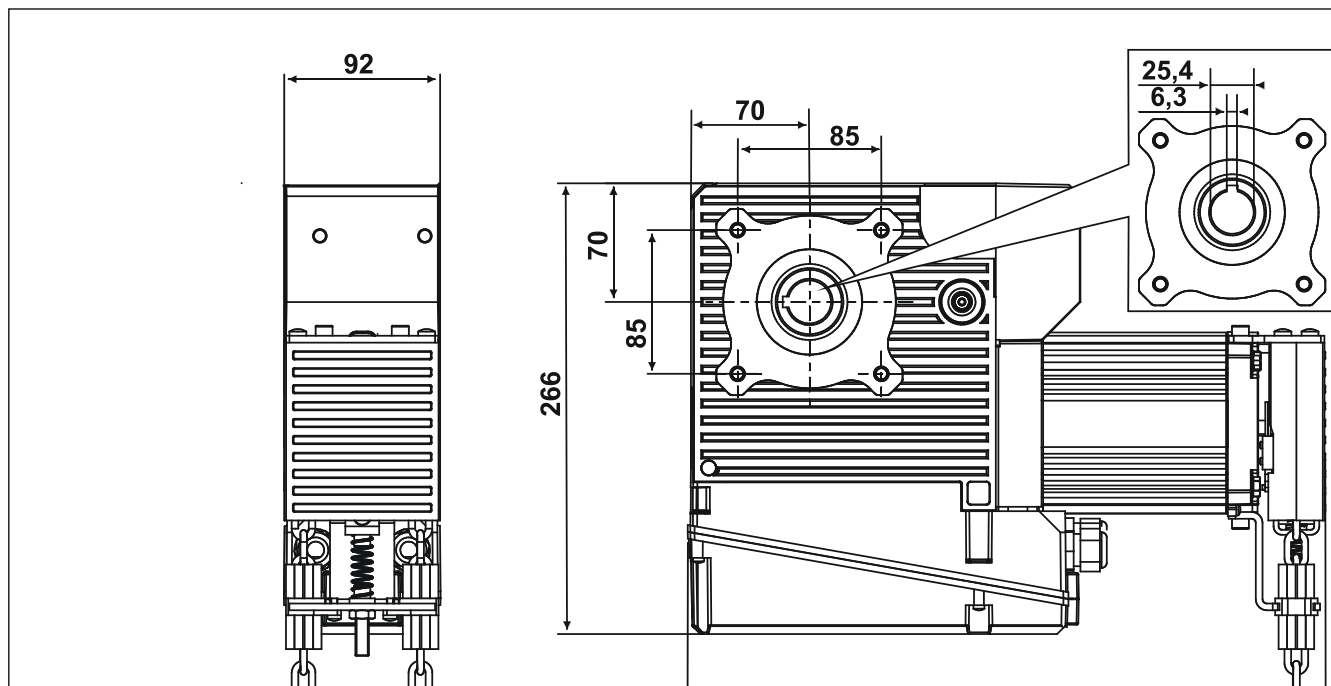

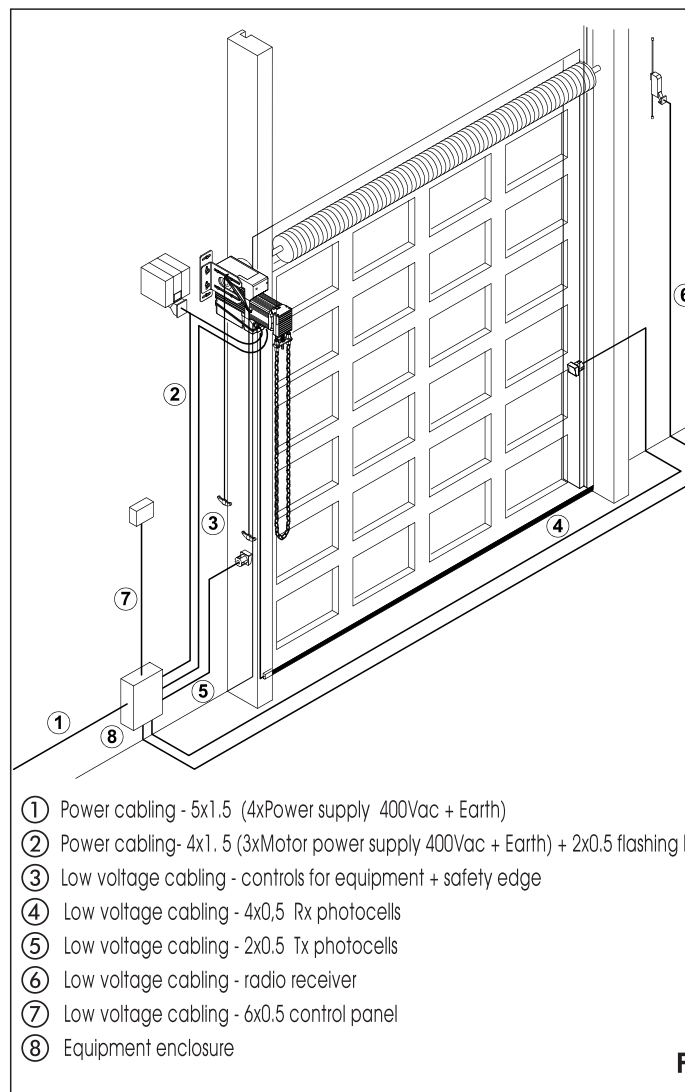
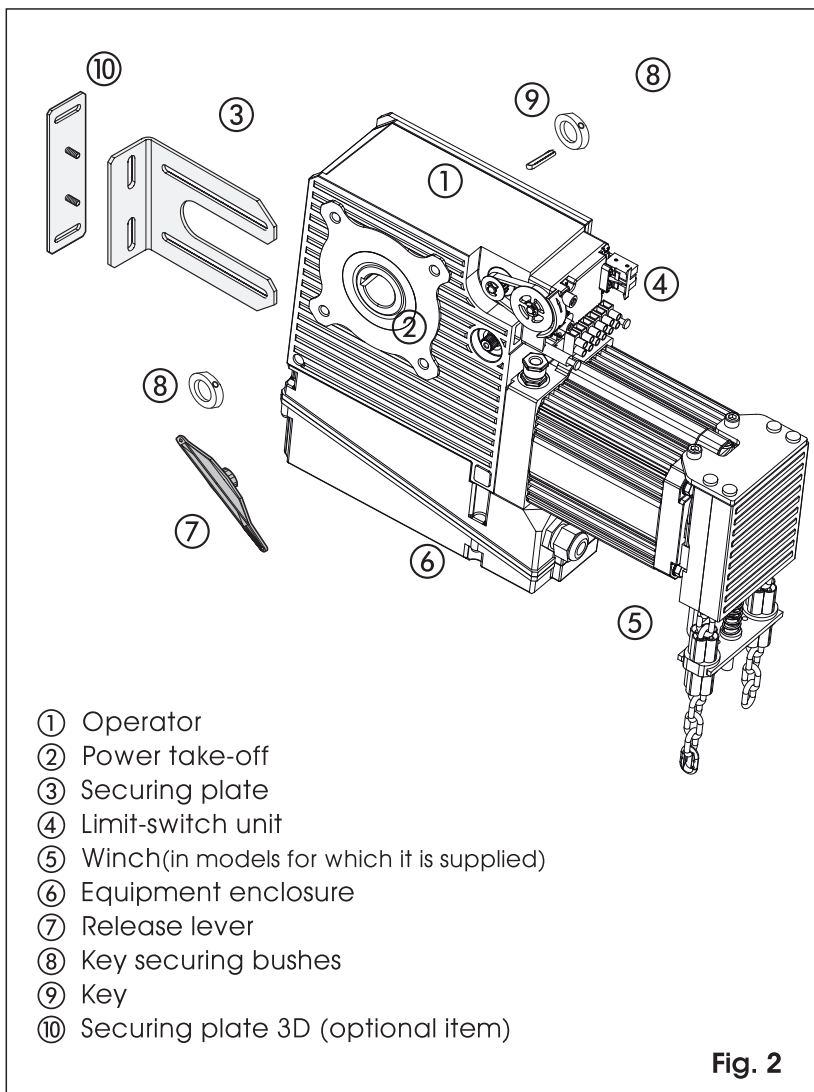

3. ELECTRICAL EQUIPMENT ARRANGEMENT

Figure 3 shows the layout of the electrical equipment required for installing the 5413ph operator with 844T remote equipment.

4. PRELIMINARY CHECKS

The door structure must be suitable to be automated and must conform to standards EN12604 and EN 12605.

The rope winding shaft must have a keyway. It must project laterally by a width sufficient to install the operator and the key locking collars (operator mounted directly on shaft) or to secure the crown-gear (mounting with chain transmission - optional item). Some door manufacturers supply special joints with shaft, which makes it possible to motorise doors which were built without the required facility. Check the efficiency of bearings, wheels, parachute system, door rail and joints. Also make sure that the traction ropes are perfectly fitted in the grooves of the drums, do not come into contact with mechanical parts or fixed parts of the structure, and are subjected to the same degree of tension.

Make sure that there is no friction on the door: the door must slide smoothly when both opening and closing.

Check if the door is well balanced: if stopped in any position, it must remain still.

Remember that European standards EN12604 and EN12453 prescribe 260N, for manually moved doors, as the maximum limit of force applied to the handles for manual manoeuvre, and 390N for motorised doors.

Consult the technical documentation of the door to find out the

fications.

The efficiency and safety of the automated system are linked to the above. You therefore must get in touch with the manufacturer or installer if you encounter any problems. Remove the door mechanical closures to ensure the door is locked by the automated system. Remove the manual activation device if supplied. Check if an efficient earthing system is available for electrical connection to the operator.

5. INSTALLING THE OPERATOR

To work under safe conditions, we advise you to install the operator while keeping the door fully closed and to read the whole manual chapter before starting to install.

The 541 3ph operator has a 25.4 mm (1") power take-off. If the power take-off shaft is of a different size, the chain transmission (optional item) must be installed.

The manual activation devices (release and chain drive) are designed for installation at a height of up to 4 metres. To install at greater heights, use the extension kits (optional items).

The operator is equipped with four microswitches with the following functions:

- Opening limit-switch
- Closing limit-switch
- Winch safety switch (only on models supplied with the manual manoeuvring system)
- Release control safety switch

The supplied support plate will enable you to secure the operator at a maximum distance of 125mm between the anchoring point (wall or metal structure) and the power take-off axis.

Before installing, we advise you to check the rotation direction of the power take-off (see paragraphs 5.7).

For all matters referring to the electrical system, please consult the manual chapter entitled "Warnings for the installer" and chapter

5.1 OPERATOR WORK POSITION

The operator - supplied with a chain-operated manual motion device - must be installed in the position shown in figure 4. In the absence of the winch, the operator can be installed in any position. If you wish to install the remote release control, first check that the release lever does not interfere with the operator's external parts. The securing plate can be installed on any of the operator's two sides.

5.3 INSTALLING THE OPERATOR

- Release the operator with the appropriate lever.
- Fit the securing plate on the operator without tightening the screws.
- Engage the power take-off on the drive shaft.
- Position the operator (see paragraph 5.1) and rest the plate on the support (wall or metal structure) on which you have decided to secure it (see figure 6.).
- Tighten the screws without forcing them, while resting the plate on the support.

- Trace the position of the installation holes.
- Remove the operator.
- Carry out the securing preparation work.
- Insert the first key securing bush and the key itself in the shaft (see fig.2 ref. 8 and 9).
- Re-install the operator with the plate released.
- Secure the plate to the support, tighten the fastening screws and secure the operator to a maximum torque of 18Nm and insert the second key securing bush.
- Secure the two bushes after positioning them in contact with the operator's power take-off.
- Lock the operator.

If you wish to weld the securing plate to the support, do this before proceeding with the operator uninstalled, and protect the drive shaft and the power take-off engagement zone. If the operator cannot be removed, it must be protected.

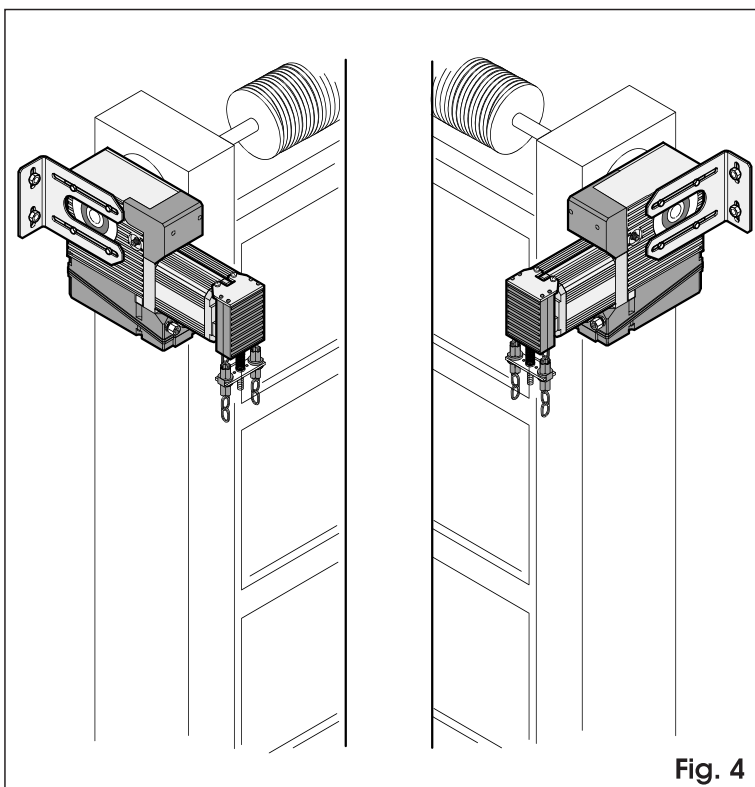
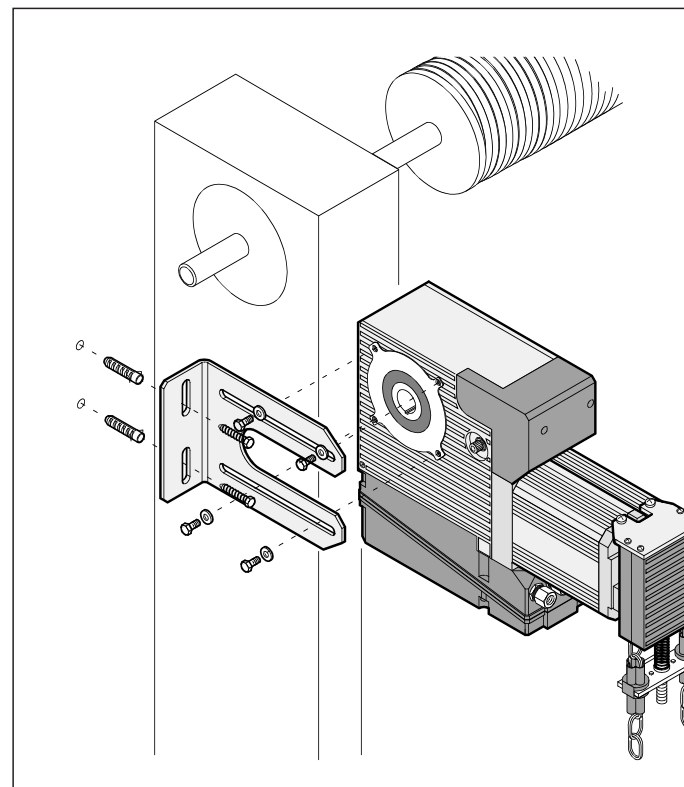

Fig. 4



5.4 WINCH ADJUSTMENT

Unwind the supplied chain completely and join one of its ends to the one already fitted to the winch, without cutting the service clip. Use one of the supplied links, selecting from those in steel (see figure 7 ref. A) or from those in plastic (see figure 7 ref.B).

The plastic links must be assembled. Tighten the steel links accurately, to allow the chain to move perfectly, inside the winch.

Cut the chain to size, without allowing the lower part of the ring it forms from touching the floor, and making sure that it is wound around itself (see figure 8).

Assemble the other side of the chain, in the same way as in figure 7. Cut the service clip only when the chain is installed.

Adjust the screw of the balancing spring (see figure 9) so that the winch support disappears completely inside the plastic enclosure (see figure 10).

Check if the traction of just one of the chain sections causes the winch to engage and, if the winch returns to its idle position when it is released.

Tighten the securing nut and make sure that operator activation is not inhibited or interrupted by the tripping of the winch safety microswitch.

We advise you to provide an anchoring point for the lower part of the chain so that it cannot hinder the transit of people or of operating means. Apply the sticker indicating the opening and closing directions, in a clearly visible way.

If you are using the chain extension kit, replace the balancing spring (fig. 9 ref. 3) with the one contained in the kit. If you are using plastic joints, we advise you to glue them together during assembly (see fig. 7 ref. B).

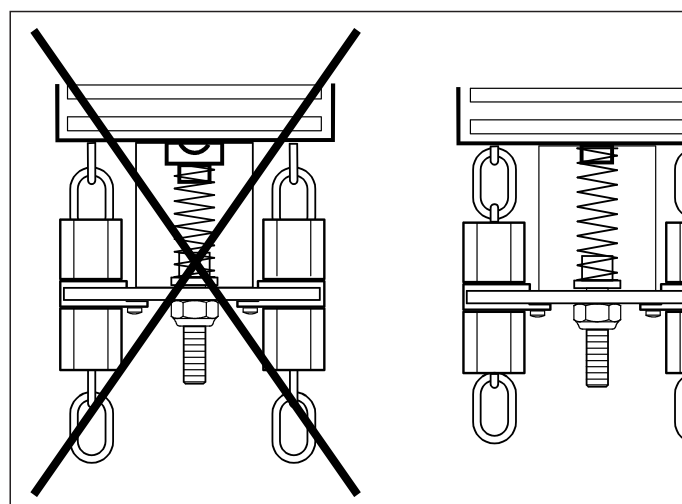
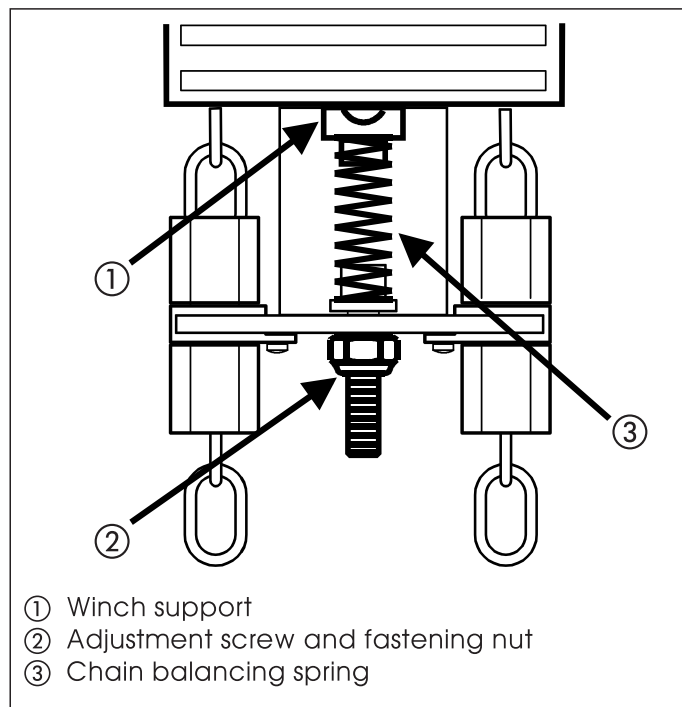
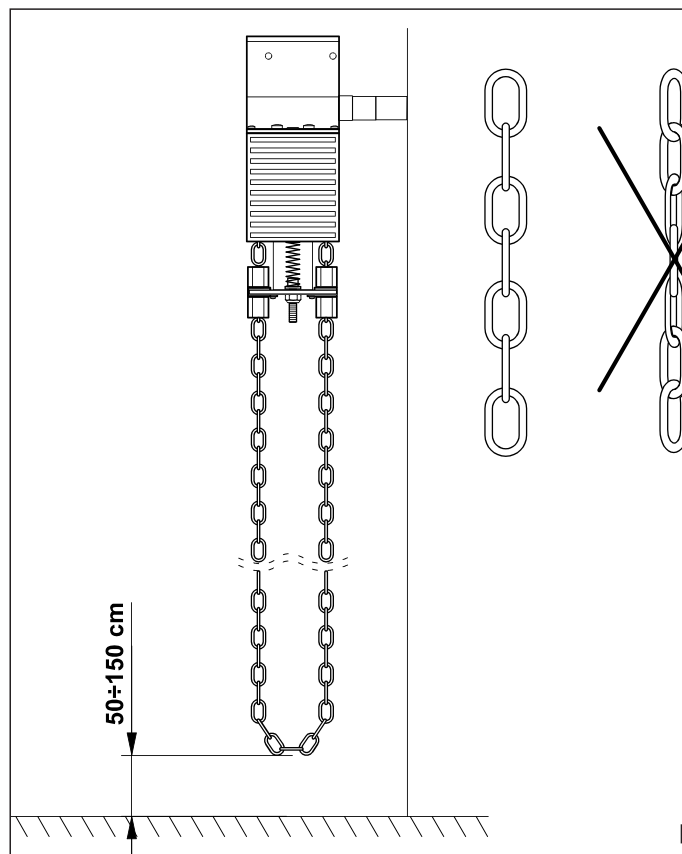
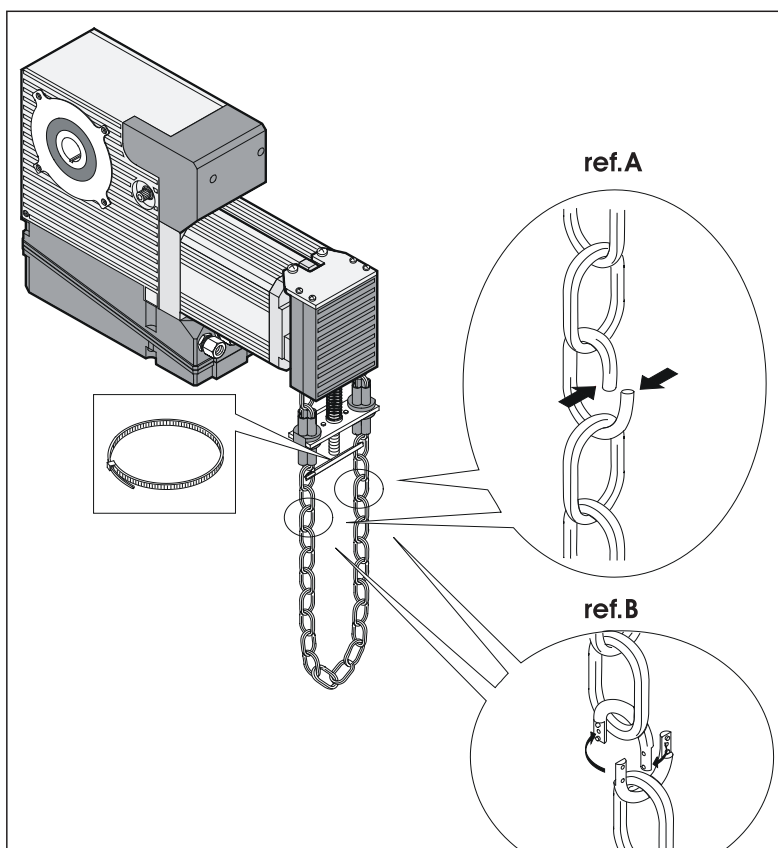

5.6 ADJUSTMENT OF LIMIT-SWITCH UNIT

The procedure for adjusting the closing and opening limit-switch is as follows:

Completely close the industrial sectional door.

Using trimmer 1, with the arrow facing down (closing), turn clockwise to + or anti-clockwise to - until the closing limit-switch is activated.

Then set the industrial sectional door in opening position.

Using trimmer 1, with the arrow facing up (opening), turn clockwise to + or anti-clockwise to - until the opening limit-switch is activated (see fig. 11).

Note for fine adjustment: the "+" symbol indicates backing away of the activator from the microswitch and therefore a longer stroke; the "-" symbol, on the contrary, indicates its approach and consequently a shorter stroke.

Final check of the open and closed positions.

Manually move the door in open and close position.

Ensure that the operator actually reaches the desired positions when opening and closing. If this does not occur, correct the limit-switch positions using trimmer 1.

If used with 578D equipment, you can correct the closing stop point also by varying the post-end of travel deceleration.

5.7 IDENTIFYING ROTATION DIRECTION (operator with equipment)

Figure 12 shows rotation directions Dir1 and Dir2. Motion in Dir1 is stopped by FC1 and motion in Dir2 direction by FC2. Consequently, for example, Dir2 is the rotation direction causing the door to close and Dir1 determines the opening point.

The OPEN command is normally associated with Dir1 motion. The stop spring of the ring-nuts activating the limit-switches, is activated by the square - the latter must not be removed until the door is adjusted.

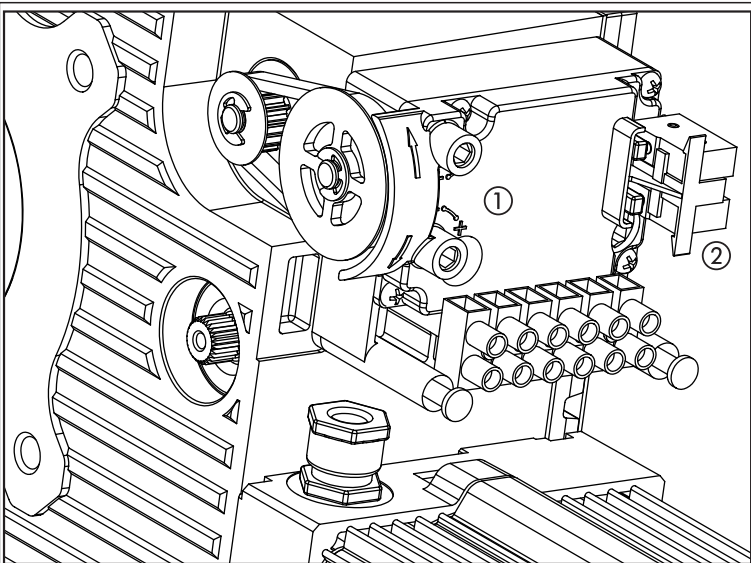

- ① Limit-switch trimmer up and down adjusting
- ② microswitch limit-switch up and down

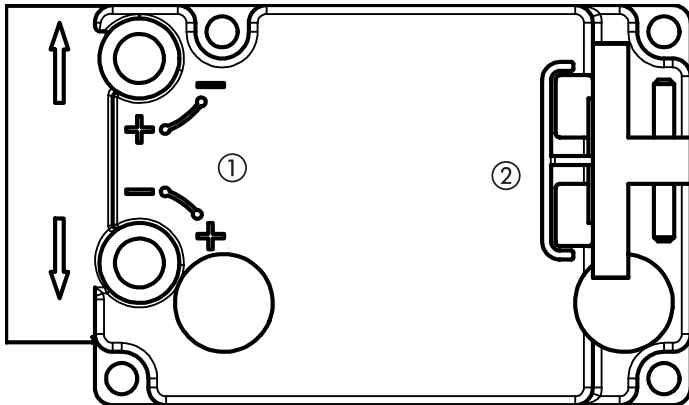
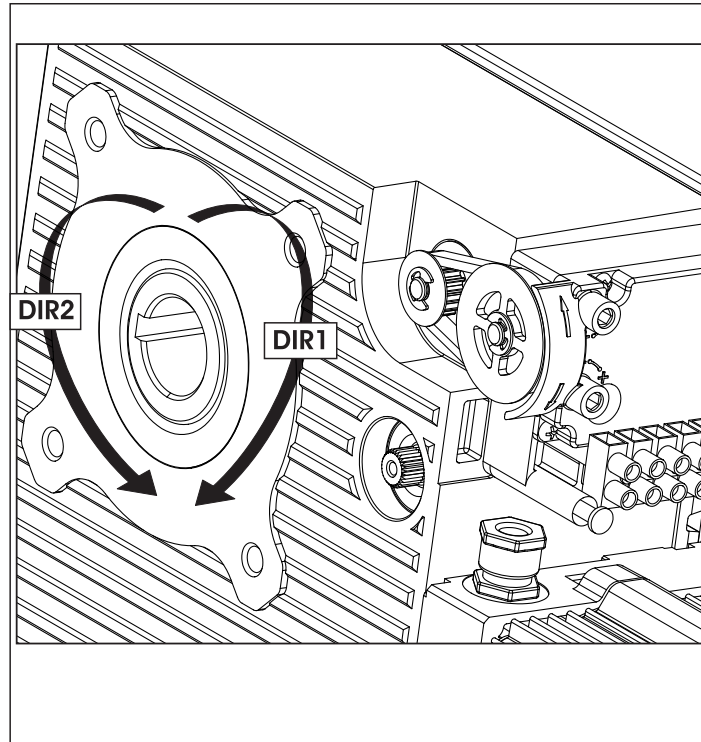
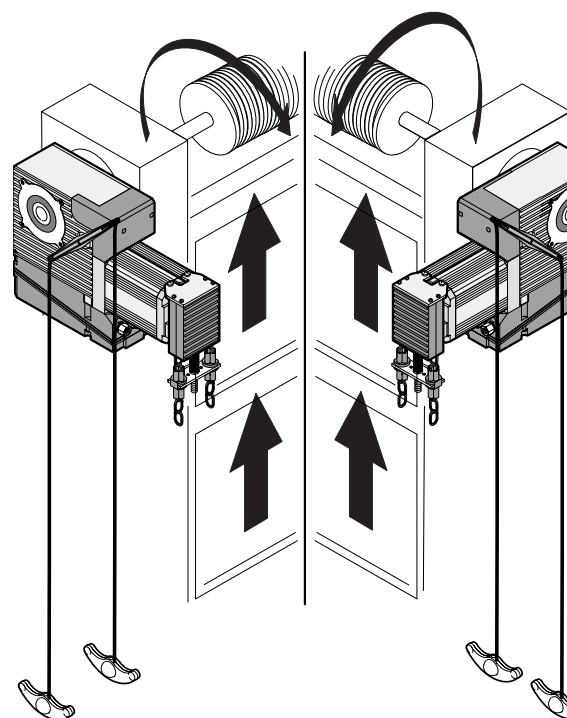
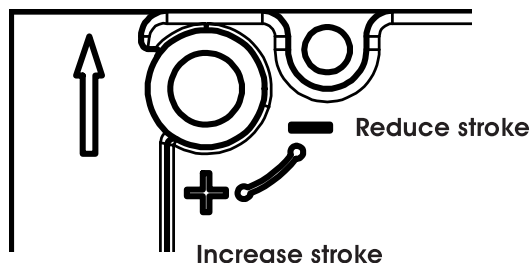

Fig. 11



Opening



Closing

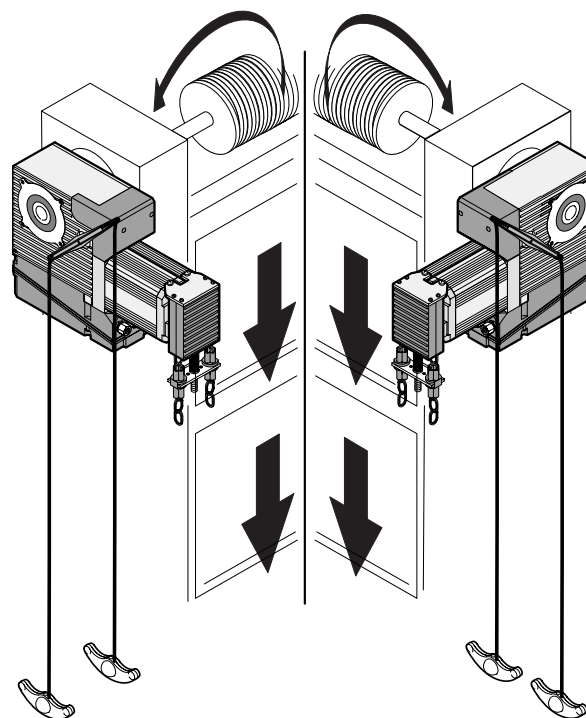
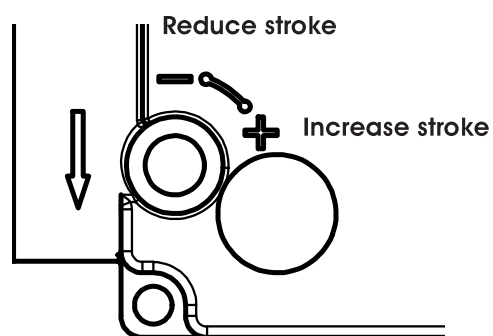

5.8 INSTALLING THE REMOTE RELEASE LEVER

Carry out the operations with the door closed.
Cut the drive ropes to measure and assemble them with the lever and knobs (see figure 15), bearing in mind that the green one must act on the lever's short arm.

In figure 16, the two side views show the position of the lever with locked operator, and the relevant positions of the release ropes (with red knob) and locking ropes (with green knob). Fit the lever and make sure that it reaches the travel limits in the two directions, at an inclination of about 45-50°.

Fit the lever fixing screw.

Make sure that the remote manoeuvre is correct and that, when the operator is in locked position, it is not prevented from operating by the release safety microswitch.

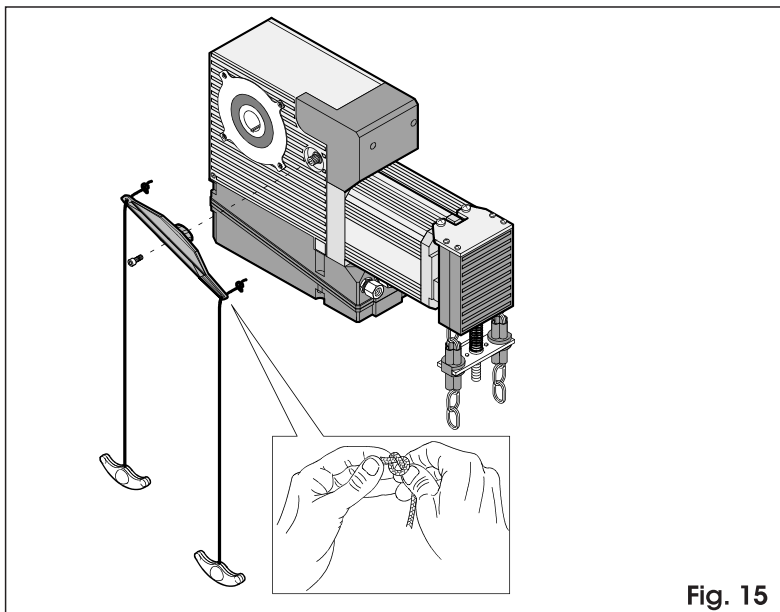

Fig. 15

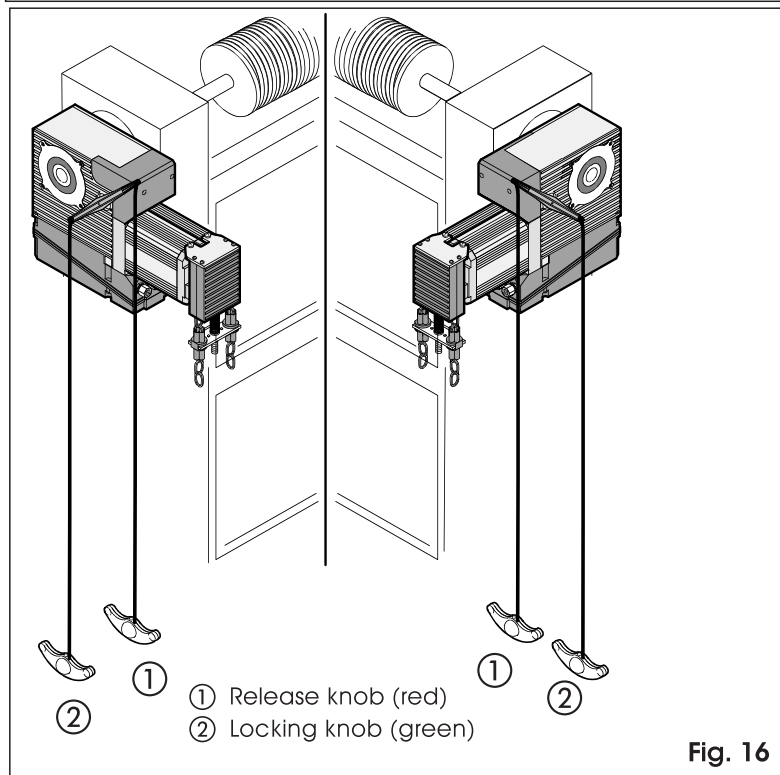

Fig. 16

6. ELECTRICAL SYSTEM

ATTENTION: Before attempting any work on the board (connection or maintenance), always turn off power.

The specifications of the electrical system are included in the manual under "Warnings for the installer". Always separate power cables from control cables.

The 541 3ph operator is supplied with an on-board inter-com connection board.

6.1 CONNECTIONS OF 844T ELECTRONIC EQUIPMENT

Lay the raceways according to the instructions in figure 4. Make the connections between the 844T unit and the 541D connection board, installed on the operator, following the diagram in figure 17.

A STOP push-button, if any, must be located in series with the connection to the connection between the STOP input of 844T and the STOP input of the 541D INTERFACE.

For wiring, and for programming the 844T, refer to the instructions for the unit.

7. START-UP

When you have carried out all the electrical connections, check the operation of the operator, and checked that the door cannot be moved manually, power up the system.

If the operator is supplied with a winch, fix it in the immediate vicinity of the chain - the sticker indicating the traction directions for the opening and closing manual manoeuvres.

7.1 541 3ph WITH 844T EQUIPMENT

Program the unit, following the instructions of the 844T unit.

8. MAINTENANCE

Maintenance: check at least every 6 months the efficiency of the system, particularly the efficiency of the safety devices (including where foreseen, the operator thrust force) and of the safety devices.

9. REPAIRS

For repairs contact an authorised FAAC Repair Centre.

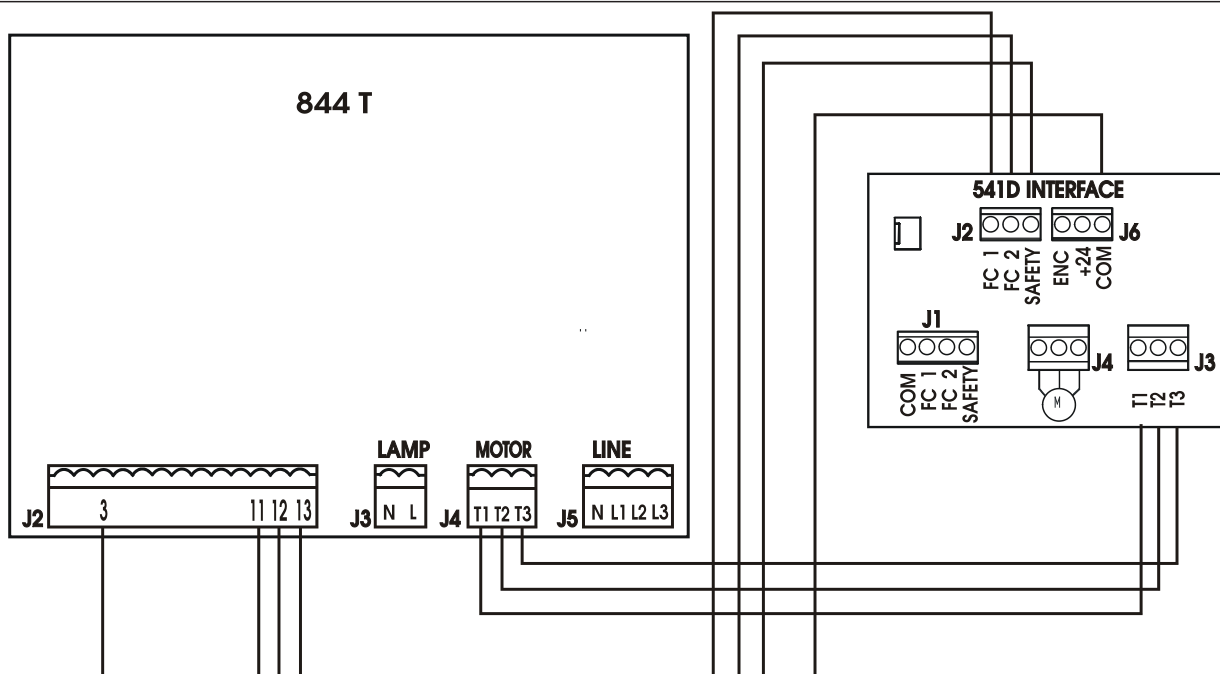

USER'S GUIDE

541 3ph AUTOMATED SYSTEMS

Read the instructions carefully before using the product and store them for future use.

GENERAL SAFETY REGULATIONS

If correctly installed and used, 541 3ph automated systems ensure a high degree of safety.

Some simple rules on behaviour can prevent accidental trouble:

- Do not, under any circumstances, stand under the sectional door.
- Do not allow children, persons or things to stand near the automated systems, especially while they are operating.
- Keep remote-controls, or other pulse generators that could open the door, well away from children.
- Do not allow children to play with the automated system.
- Do not willingly obstruct door movement.
- Prevent any branches or shrubs from interfering with door movement.
- Keep warning-lights efficient and easy to see.
- Do not attempt to activate the door by hand unless you have released it.
- Make sure that there are no persons, animal or things near the door before releasing the door.
- In the event of malfunctions, manually activate or release the door to allow access and wait for qualified technical personnel to do the necessary work.
- When the operator is released, before restoring motorised operation, make sure that the system is not powered.
- Do not in any way modify the components of the automated system.
- Do not attempt any kind of repair of direct action whatever and contact qualified FAAC personnel only.
- At least every six months: arrange for qualified personnel to check efficiency of the automated system, safety devices and earth connection.
- Arrange for qualified personnel to check the door at the intervals recommended by the manufacturer, addressing special attention to the safety systems and balancing.
- Transit under the door is permitted only when the automated system is idle.

DESCRIPTION

The 541 3ph automated systems are ideal for activating balanced industrial sectional doors.

They consist of an electro-mechanical operator and remote electronic control equipment. The non-reversing system ensures mechanical locking of the door when the motor is not operating and, therefore, no lock needs to be installed. Operator release and a manual manoeuvring system (the latter is only supplied on the models for which it is specified), make the door manoeuvrable in the event of a power cut or malfunction.

The door is normally closed; when opening is commanded, the equipment activates the electric motor which drives the door to opening position to permit access. In "dead-man" systems, the command push-button must be kept pressed for the whole duration of the opening or closing manoeuvre.

In the automatically operating systems:

- If the automatic logic was set, the door closes after pause time has elapsed.
- If the semi-automatic logic was set, a second pulse must be sent to close the door.
- A stop pulse (if supplied) always stops movement.

For full details on the behaviour of the automated system in the different logics, consult the installation Technician.

Automated systems may include safety devices (sensitive edges, photocells) that prevent the door from closing and/or opening when there is an obstacle in the area they protect. Emergency manual

Manual command is possible by activating the chain-operated winch (for models with which it is supplied).

Electric command is disabled during the manual manoeuvre when the operator is released.

The warning-light, where supplied, indicates that the door is currently moving.

MANUAL OPERATION (541 3ph with winch)

If the door has to be activated and the automated system is inactive due to a power-cut or malfunction, the door opening or closing manoeuvres can be done by hand, by using the chain-operated winch. Check the indicator sign to see which branch of the chain has to be activated to perform the required manoeuvre. Pull downward only the branch involved.

If no indicator sign is present, pull one of the chain branches without forcing and check if the door tends to move in the required direction. If not, activate the other branch. While the winch is operating, the operator's electrical command is disabled.

RELEASING THE OPERATOR AND RESTORING AUTOMATIC OPERATION

The 541 3ph operators are provided with an emergency release which can be activated from the inside.

The operator release operation must be effected with the door closed if possible. In any event, the presence of persons, animals and objects in the immediate vicinity of the operator is absolutely forbidden.

If the door has to be moved manually due to a power cut or malfunction of the automated system, cut out power to the system and use the release device as follows: release the operator by pulling the rope with the red knob (see figure 1) downward until the rope reaches the travel-limit stop. To restore automatic operation, close the door and pull the rope with the green knob until the operator returns to its original position.

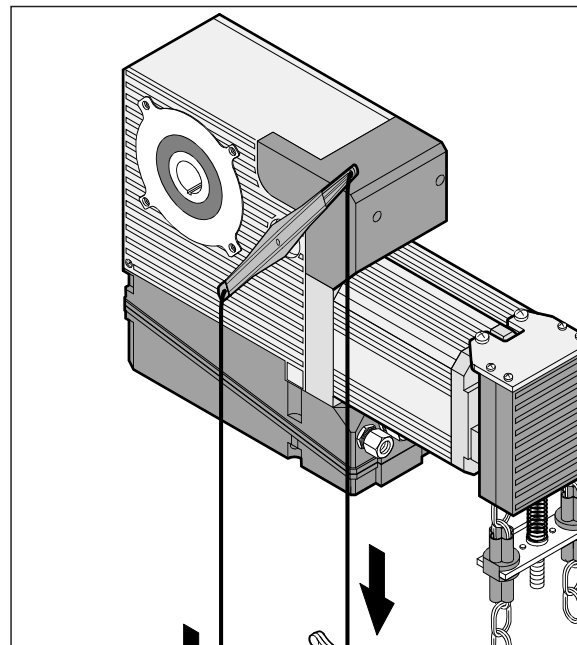

Le descrizioni e le illustrazioni del presente manuale non sono impegnative. La FAAC si riserva il diritto, lasciando inalterate le caratteristiche essenziali dell'apparecchiatura, di apportare in qualunque momento e senza impegnarsi ad aggiornare la presente pubblicazione, le modifiche che essa ritiene convenienti per miglioramenti tecnici o per qualsiasi altra esigenza di carattere costruttivo o commerciale.

The descriptions and illustrations contained in the present manual are not binding. FAAC reserves the right, whilst leaving the main features of the equipments unaltered, to undertake any modifications it holds necessary for either technical or commercial reasons, at any time and without revising the present publication.

Les descriptions et les illustrations du présent manuel sont fournies à titre indicatif. FAAC se réserve le droit d'apporter à tout moment les modifications qu'elle jugera utiles sur ce produit tout en conservant les caractéristiques essentielles, sans devoir pour autant mettre à jour cette publication.

Die Beschreibungen und Abbildungen in vorliegendem Handbuch sind unverbindlich. FAAC behält sich das Recht vor, ohne die wesentlichen Eigenschaften dieses Gerätes zu verändern und ohne Verbindlichkeiten in Bezug auf die Neufassung der vorliegenden Anleitungen, technisch bzw. konstruktiv/kommerziell bedingte Verbesserungen vorzunehmen.

Las descripciones y las ilustraciones de este manual no comportan compromiso alguno. FAAC se reserva el derecho, dejando inmutadas las características esenciales de los aparatos, de aportar, en cualquier momento y sin comprometerse a poner al día la presente publicación, todas las modificaciones que considere oportunas para el perfeccionamiento técnico o para cualquier otro tipo de exigencia de carácter constructivo o comercial.

De beschrijvingen in deze handleiding zijn niet bindend. FAAC behoudt zich het recht voor op elk willekeurig moment de veranderingen aan te brengen die het bedrijf nuttig acht met het oog op technische verbeteringen of alle mogelijke andere productie- of commerciële eisen, waarbij de fundamentele eigenschappen van de apparaat gehandhaafd blijven, zonder zich daardoor te verplichten deze publicatie bij te werken.
