

620/640/642

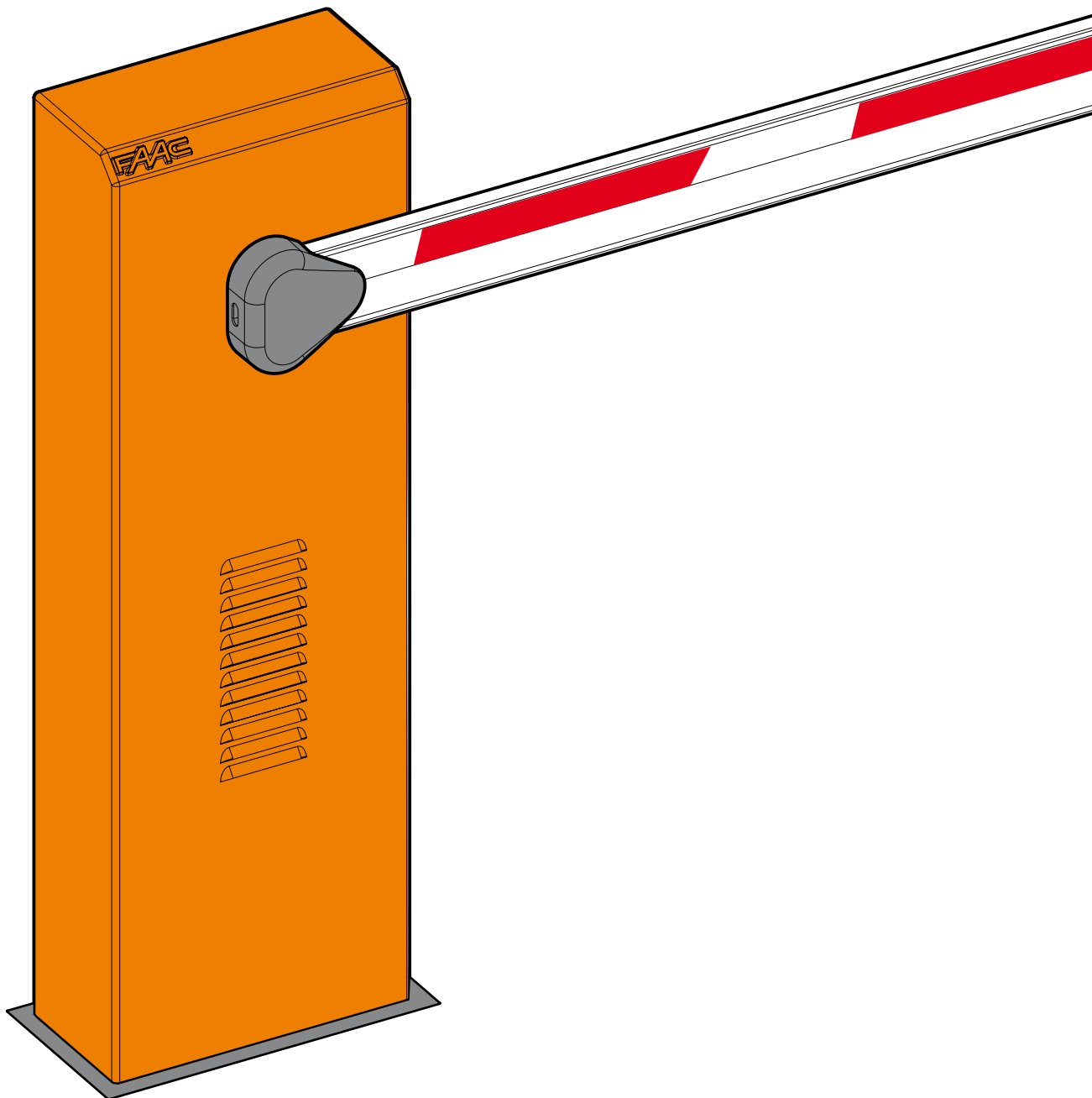

Leggere completamente questo manuale di istruzioni prima di iniziare l'installazione del prodotto.



Il simbolo evidenzia le note importanti per la sicurezza delle persone e l'integrità dell'automazione.



Il simbolo richiama l'attenzione sulle note riguardanti le caratteristiche od il funzionamento del prodotto.

Read this instruction manual to the letter before you begin to install the product.



Symbol highlights notes that are important for people's safety and for the good condition of the automated system.



Symbol draws your attention to the notes about the product's characteristics or operation.

Lire ce manuel d'instructions dans son entier avant de commencer l'installation du produit.



Le symbole met en évidence les remarques pour la sécurité des personnes et le parfait état de l'automatisme.



Le symbole attire l'attention sur les remarques concernant les caractéristiques ou le fonctionnement du produit.

Vor der Installation des Produkts sind die Anweisungen vollständig zu lesen.



Mit dem Symbol sind wichtige Anmerkungen für die Sicherheit der Personen und den störungsfreien Betrieb des Produkts gekennzeichnet.



Mit dem Symbol wird auf Anmerkungen zu den Eigenschaften oder dem Betrieb des Produkts verwiesen.

Lean completamente este manual de instrucciones antes de empezar la instalación del producto.



El símbolo identifica notas importantes para la seguridad de las personas y para la integridad de la automatización.



El símbolo llama la atención sobre las notas relativas a las características o al funcionamiento del producto.

Lees deze instructiehandleiding helemaal door alvorens het product te installeren.



Het symbool is een aanduiding van opmerkingen die belangrijk zijn voor de veiligheid van personen en voor een goede automatische werking.



Het symbool vestigt de aandacht op opmerkingen over de eigenschappen of de werking van het product.

# INDEX

- CE DECLARATION OF CONFORMITY FOR MACHINES.....**
- WARNINGS FOR THE INSTALLER .....**
- 1. DESCRIPTION AND TECHNICAL SPECIFICATIONS .....**
  - 1.1 MAXIMUM USE CURVE.....**
- 2 ELECTRIC PREPARATIONS (standard system).....**
- 3 DIMENSIONS .....**
  - 3.1 BARRIER 620 .....**
  - 3.2 BARRIER 640 - 642 .....**
- 4 INSTALLING THE AUTOMATED SYSTEM .....**
  - 4.1 PRELIMINARY CHECKS .....**
  - 4.2 MASONRY FOR FOUNDATION PLINTH.....**
  - 4.3 MECHANICAL INSTALLATION .....**
    - 4.3.1 BARRIER 620.....**
    - 4.3.2 BARRIER 640 - 642.....**
  - 4.4 ADJUSTING THE BALANCING SPRING .....**
- 5 START-UP.....**
  - 5.1 CONNECTION TO CONTROL BOARD .....**
  - 5.2 ADJUSTING THE TRANSMITTED TORQUE.....**
  - 5.3 ADJUSTING THE TRAVEL LIMIT SLOW DOWN.....**
  - 5.4 AUTOMATED SYSTEM TEST.....**
- 6 MANUAL MODE OPERATION .....**
- 7 RESTORING NORMAL OPERATION MODE.....**
- 8 MAINTENANCE .....**
  - 8.1 TOPPING UP OIL .....**
  - 8.2 BLEEDING OPERATION .....**
- 9 REPAIRS.....**
- 10 CHANGING THE RH (LH) VERSION OF THE BARRIER INTO THE LH (RH) VERSION.....**
- 11 AVAILABLE ACCESSORIES .....**
- 12 DETAILED TECHNICAL SPECIFICATIONS.....**

## CE DECLARATION OF CONFORMITY FOR MACHINES (DIRECTIVE 98/37/EC)

**Manufacturer:** FAAC S.p.A.

**Address:** Via Benini, 1 - 40069 Zola Predosa BOLOGNA - ITALY

**Declares that:** Barrier mod. 620, mod. 640, mod. 642,

- is built to be integrated into a machine or to be assembled with other machinery to create a machine under the provisions of Directive 98/37/EEC and subsequent amendments 91/368 EEC, 93/44 EEC and 93/68 EEC;
- conforms to the essential safety requirements of the other following EEC directives:

73/23/EEC and subsequent amendment 93/68/EEC.  
89/336/EEC and subsequent amendment 92/31/EEC and 93/68/EEC

Furthermore, the manufacturer declares that the machinery must not be put into service until the machine or part of which it will be integrated or of which it will become a component has been identified and its conformity to the conditions of Directive 89/392/EEC and subsequent modifications assimilated in Italian National legislation under Presidential Decree No. 459 of 24 July 1996 has been declared.

Bologna, 01 June 2007

The Managing Director

A. Bassi  

## WARNINGS FOR THE INSTALLER

### GENERAL SAFETY OBLIGATIONS

- 1) **ATTENTION! To ensure the safety of people, it is important that you read all the following instructions. Incorrect installation or incorrect use of the product could cause serious harm to people.**
- 2) Carefully read the instructions before beginning to install the product.
- 3) Do not leave packing materials (plastic, polystyrene, etc.) within reach of children as such materials are potential sources of danger.
- 4) Store these instructions for future reference.
- 5) This product was designed and built strictly for the use indicated in this documentation. Any other use, not expressly indicated here, could compromise the good condition/operation of the product and/or be a source of danger.
- 6) FAAC declines all liability caused by improper use or use other than that for which the automated system was intended.
- 7) Do not install the equipment in an explosive atmosphere: the presence of inflammable gas or fumes is a serious danger to safety.
- 8) The mechanical parts must conform to the provisions of Standards EN 12604 and EN 12605.  
  
For non-EU countries, to obtain an adequate level of safety, the Standards mentioned above must be observed, in addition to national legal regulations.
- 9) FAAC is not responsible for failure to observe Good Technique in the construction of the closing elements to be motorised, or for any deformation that may occur during use.
- 10) The installation must conform to Standards EN 12453 and EN 12445.  
  
For non-EU countries, to obtain an adequate level of safety, the Standards mentioned above must be observed, in addition to national legal regulations.
- 11) Before attempting any job on the system, cut out electrical power.
- 12) The mains power supply of the automated system must be fitted with an all-pole switch with contact opening distance of 3mm or greater. Use of a 6A thermal breaker with all-pole circuit break is recommended.
- 13) Make sure that the efficiency of the system is not reduced by the use of a 0.02 A inrush current limiter.
- 14) Make sure that the earthing system is perfectly constructed, and connect the metal parts of the means of the closure to it.
- 15) The automated system is supplied with an intrinsic anti-crushing device consisting of a torque control. Nevertheless, its tripping threshold must be checked as specified in the Standards indicated at point 15).
- 16) The safety devices (EN 12978 standard) protect any danger against **mechanical movement Risks**, such as crushing, dragging, shearing.
- 17) Use of at least one indicator-light (e.g. FAACLIGHT) is recommended for every system, as well as a warning sign adequately secured to the frame structure, in addition to the devices mentioned at point 17).
- 18) FAAC declines all liability as concerns safety and efficient operation of the automated system, if system components not produced by FAAC are used.
- 19) For maintenance, strictly use original parts by FAAC.
- 20) Do not in any way modify the components of the automated system.
- 21) The installer shall supply all information concerning manual operation of the system in case of an emergency, and shall hand over to the user the warnings handbook supplied with the product.
- 22) Do not allow children or adults to stay near the product while it is operating.
- 23) Keep radiocontrols or other pulse generators away from children to prevent the automated system from being activated involuntarily.
- 24) Transit is permitted only when the automated system is idle.
- 25) The user must not attempt any kind of repair or direct action which could be dangerous and contact qualified personnel only.
- 26) Maintenance: check at least every 6 months the efficiency of the system, particularly the efficiency of the safety devices (including the force foreseen, the operator thrust force) and of the release devices.
- 27) **Anything not expressly specified in these instructions is not permitted.**

## AUTOMATED SYSTEM 620 - 640 - 642

The automated system consists of a white beam in aluminium, with reflex reflectors and a steel upright. The operator is located inside the upright, and consists of a hydraulic control unit and two plunging pistons which, by means of a rocker, rotate the beam. The beam stays balanced thanks to a balancing spring assembled on one of the plunging pistons. The electronic control unit is also housed in the upright, inside a waterproof compartment. The system is supplied with an adjustable anti-crushing safety device. It also includes a device stopping and locking the beam in any position, and a handy manual release for use in case of power cuts or faults.

The 620 - 640 - 642 automated systems were designed and built to control vehicle access. Do not use for any other purpose.

ENGLISH

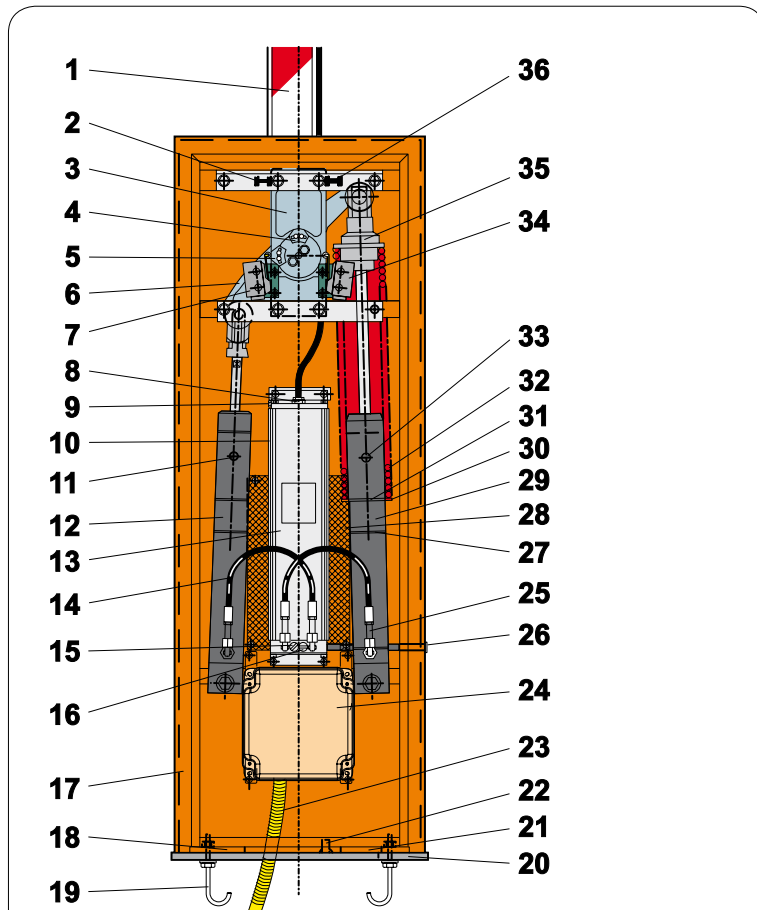

- |                                       |   |
|---------------------------------------|---|
| 1 Beam                                | 19 Tie rod                                |
| 2 Travel limit mechanical stop device | 20 Foundation plate                       |
| 3 Drive transmission unit             | 21 Hole for cables RH                     |
| 4 Adjustable travel limit cam RH      | 22 Earth connector securing screw         |
| 5 Adjustable travel limit cam LH      | 23 Cable routing sheath                   |
| 6 Rocker                              | 24 Electronic control board               |
| 7 LH travel limit device              | 25 Feeder pipe RH                         |
| 8 Oil filling plug                    | 26 Manual release                         |
| 9 Breather screw                      | 27 Spring support position length: 460 mm |
| 10 Cooling fins                       | 28 Protective grid for air intakes        |
| 11 Piston bleed screw LH              | 29 Plunging piston RH                     |
| 12 Plunging piston LH                 | 30 Spring support position length: 400 mm |
| 13 Hydraulic control unit             | 31 Balancing spring support               |
| 14 Feeder pipe LH                     | 32 Balancing spring                       |
| 15 CLOSING by-pass screw              | 33 Piston bleed screw RH                  |
| 16 OPENING by-pass screw              | 34 Travel limit device RH                 |
| 17 Upright                            | 35 Balancing adjustment ring-out          |

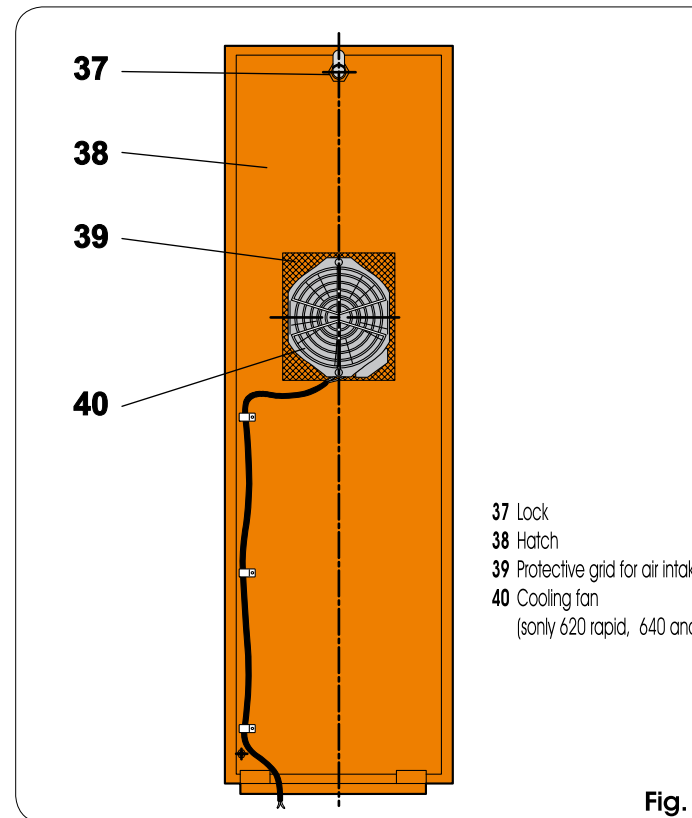

- 37 Lock
- 38 Hatch
- 39 Protective grid for air intake
- 40 Cooling fan (only 620 rapid, 640 and 642)

Fig.

### 1. DESCRIPTION AND TECHNICAL SPECIFICATIONS

TAB. 1 Technical specifications (\*)

BARRIER MODEL	620	640	642
Power supply (Vac / Hz)	230 {+6% / -10%} / 50		
Absorbed power (W)	220		
Absorbed current (A)	1		
Type of oil	FAAC HP OIL		
Oil quantity (Lt)	~ 1.8		
Winding heat protection (°C)	120		
Anti-crushing system	standard by-pass valves		
Type of slow-down	Electronic		
Operating ambient temperature (°C)	-20 / +55		
Hood protective treatment	Cataphoresis	AISI 304 stainless steel	
Hood painting	Polyester RAL 2004		
Protection class	IP44		
Upright dimensions LxHxP (mm)	see Fig. 4 and 5		

(\*) For more details about the selected barrier model, refer to chapter 12

TECHNICAL DETAILS OF 1400 rpm ELECTRIC MOTOR	
Power supply (Vac{+6% / -10%}/Hz)	230 / 50
Absorbed power (W)	200
Absorbed current (A)	1

TECHNICAL DETAILS OF 2800 rpm ELECTRIC MOTOR	
--	--

### 1.1 MAXIMUM USE CURVE

The curve makes it possible to establish maximum work time (T) according to use frequency (F).

E.g.: Operators 620 rapid, 640, 642 R/40 and 642/70 can operate non-stop at 100% use frequency as they are provided with a cooling fan. Models 620 standard and 642 std/40 can operate non-stop at 70% use frequency.

To ensure efficient operation, operate in the work range under the curve.

#### Use frequency graph

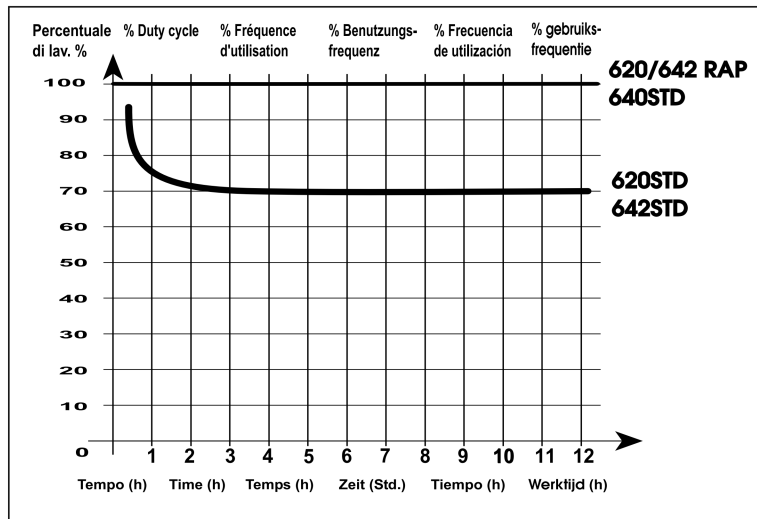

**Important:** The curve is obtained at a temperature of 24 °C. Exposure to the direct sun rays can reduce use frequency down to 20%

#### Calculation of use frequency

The percentage of effective work time (opening + closing) compared to total time of cycle (opening + closing + pause times).

Calculation formula:

$$\%F = \frac{T_a + T_c}{T_a + T_c + T_p + T_i} \times 100$$

where:

T<sub>a</sub> = opening time

T<sub>c</sub> = closing time

T<sub>p</sub> = pause time

T<sub>i</sub> = interval time between one complete cycle and another

### 2 ELECTRIC PREPARATIONS (standard system)

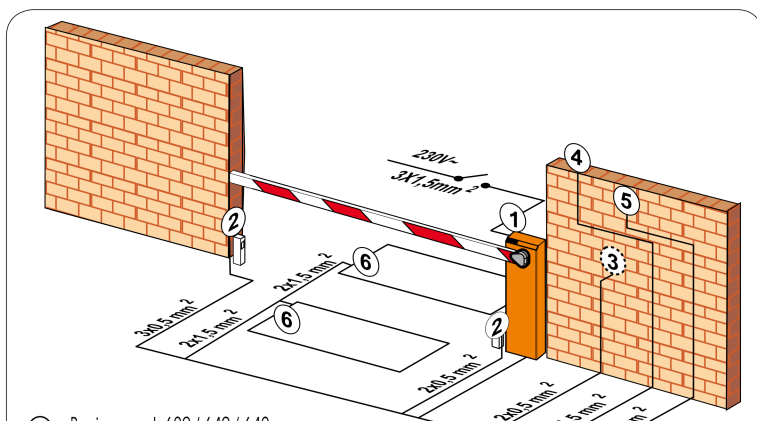

#### Notes:

- 1) To lay cables, use adequate rigid and/or flexible tubing.
- 2) Always separate connection cables of low voltage accessories from those operating at 230v~. To prevent interference whatever, use separate sheaths.

### 3 BARRIER DIMENSIONS

#### 3.1 BARRIER 620

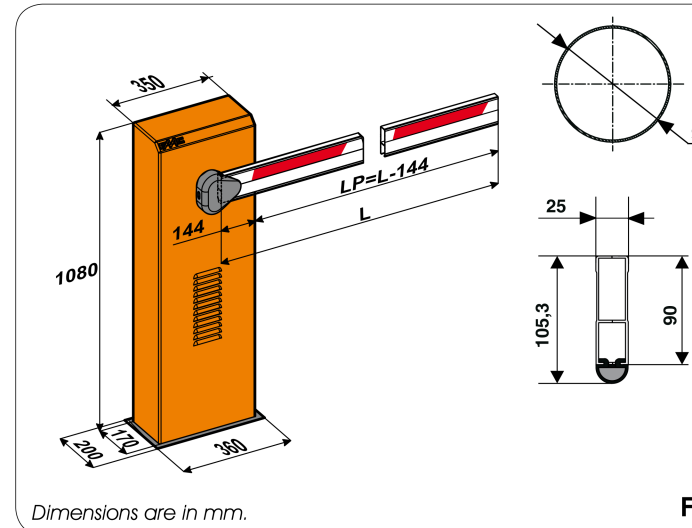

#### 3.2 BARRIERS 640 - 642

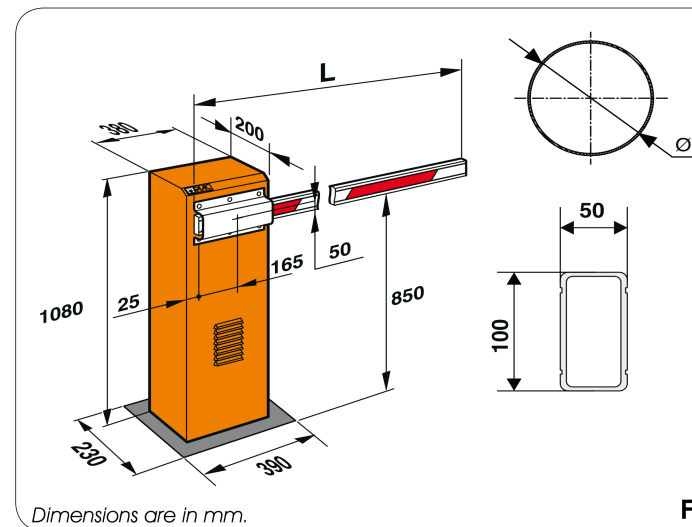

### 4 INSTALLING THE AUTOMATED SYSTEM

#### 4.1 PRELIMINARY CHECKS

To ensure safety and an efficiently operating automated system, make sure the following conditions are observed:

- When moving, the beam must not, on any account, touch any obstacles or overhead power cables.
- The soil must permit sufficient stability for the foundation plinth.
- There must be no pipes or electrical cables in the excavation area.
- If the barrier body is exposed to passing vehicles, in any case, adequate means of protection against accidental impact.
- Check if an efficient earth socket is available for connecting the upright.

#### 4.2 MASONRY FOR FOUNDATION PLINTH

- 1) Assemble the foundation plate as in fig.6. ref. ①
- 2) Make a foundation plinth as shown in fig.4 ref.② (referred to clayey soil)
- 3) Wall the foundation plinth as shown in fig.6, ref.②, supplying one or more sheaths for routing electrical cables. Using a spirit level, check if the plate is perfectly level. Wait for the cement to set.

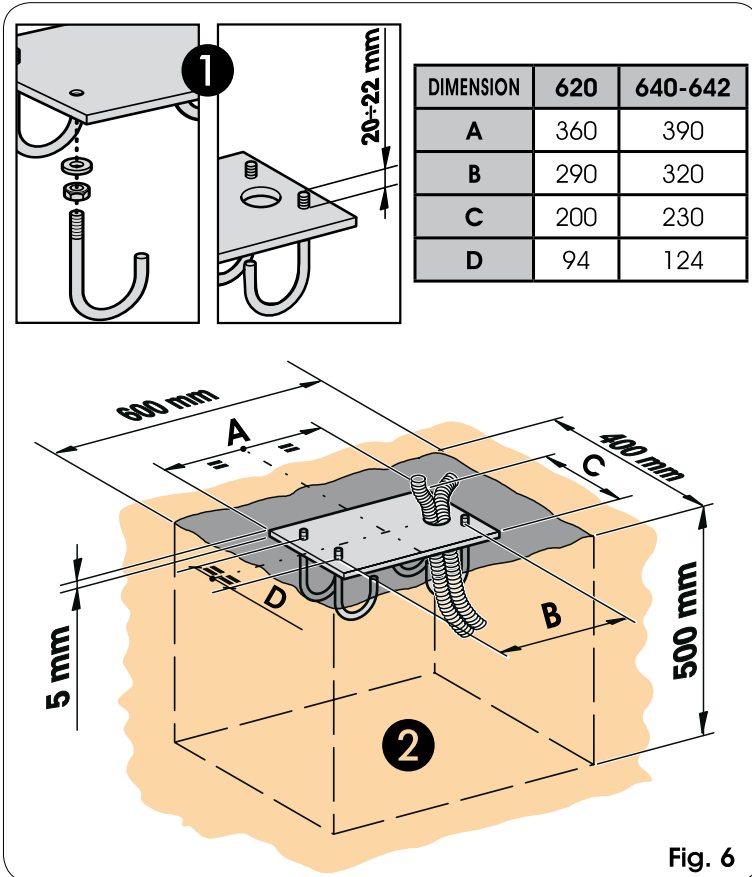

#### 4.3 MECHANICAL INSTALLATION

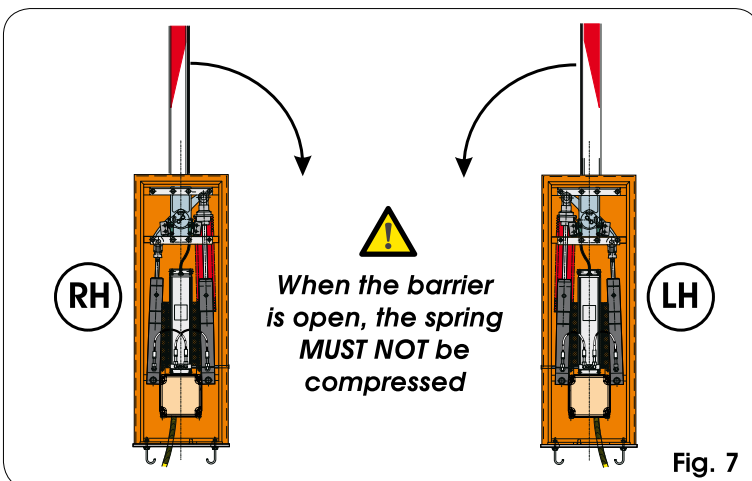

- 1) Fasten the upright on the foundation plate using the four supplied nuts (fig.8) and checking the configuration of the barrier as in figure 7. Remember that the hatch of the upright should normally face the building.
- 2) Set the operator for manual operation as described in chapter 6.
- 3) Remove and store the breather screws as shown in Fig.9.
- 4) Assemble the beam, using the supplied screws, as shown in figures 10 or 11 (The rubber profile of the beam must face in closing direction).
- 5) Adjust the opening and closing travel limit mechanical stops

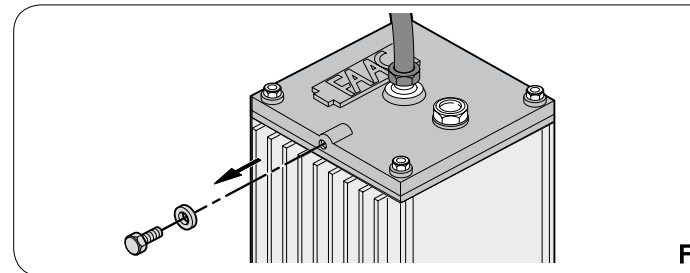
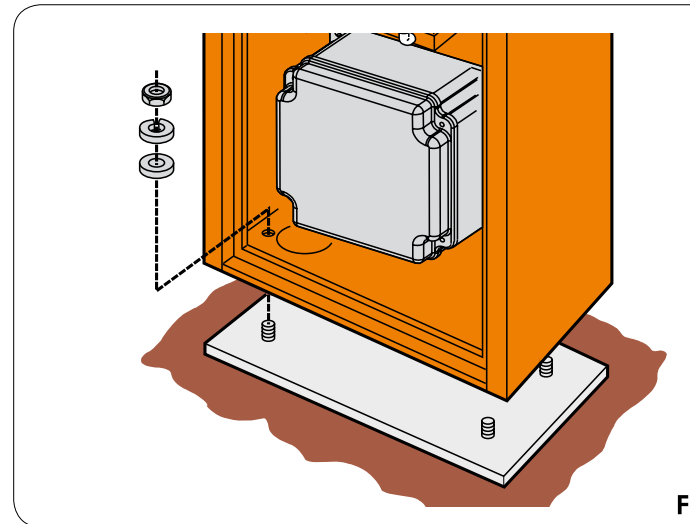

#### 4.3.1 BARRIER 620

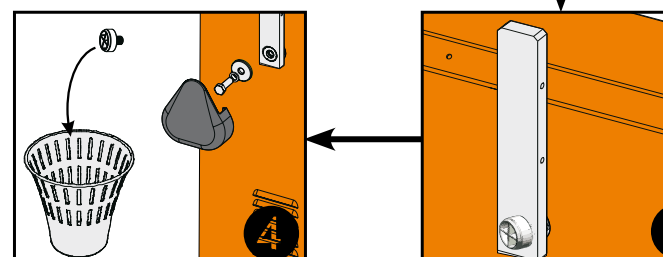
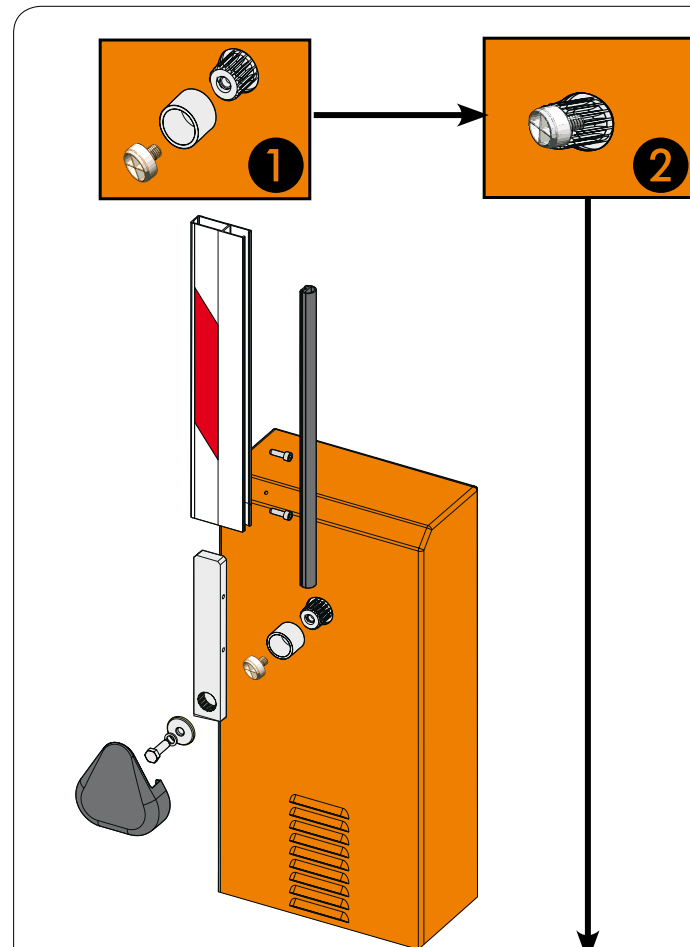

4.3.1 BARRIER 640 - 642

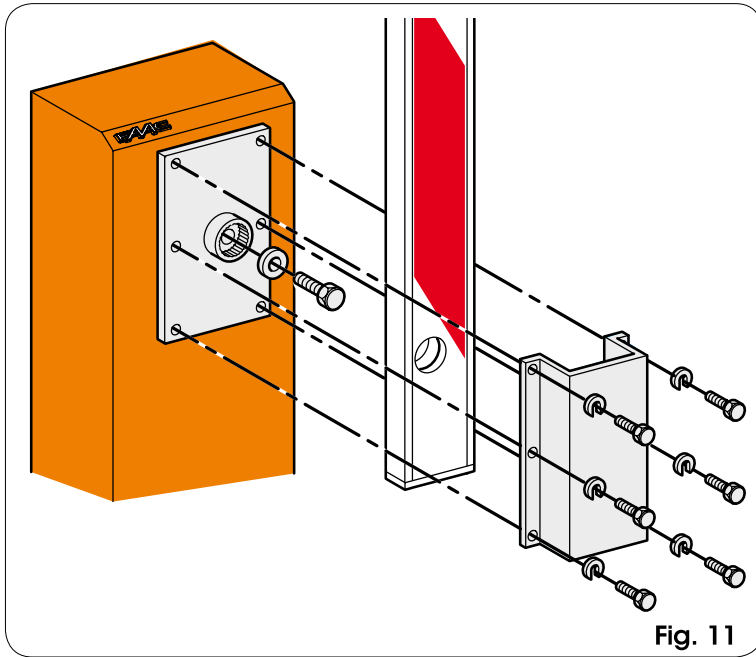

Fig. 11

4.4 ADJUSTING THE BALANCING SPRING.

**IMPORTANT:** The barrier is supplied already balanced for the exact length of the beam indicated in the order.  
(The barrier is balanced when the beam stays idle in the 45° position)

For any fine tuning of barrier balancing, proceed as follows:

- 1) Make sure that the operator is released: see chapter 6.
- 2) If the barrier tends to close, turn the spring pre-loading ring-nut (Fig.12 ref.②) clockwise, if it tends to open, turn it anti-clockwise.

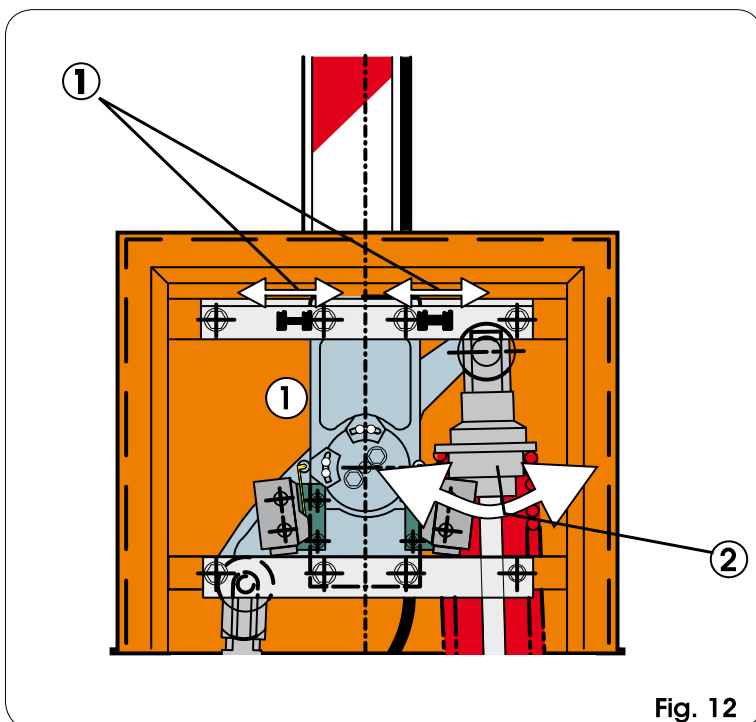

Fig. 12

5 START-UP

5.1 CONNECTION TO CONTROL BOARD

**IMPORTANT:** Before all the wiring proceed on the control board

For the electrical connections, refer to the dedicated instructions of the control board.

Observing the indications in fig.3, install the raceways and the electrical connections from the electronic appliance selected accessories.

Always separate power cables from control and safety (push-button receiver, photocells, etc.).

5.2 ADJUSTING THE TRANSMITTED TORQUE

To set the hydraulic system for controlling transmitted torque the two by-pass screws (Fig. 13).

The red screw controls closing movement torque.

The green screw controls opening movement torque.

To increase torque, turn the screws clockwise.

To reduce torque, turn the screws anti-clockwise.

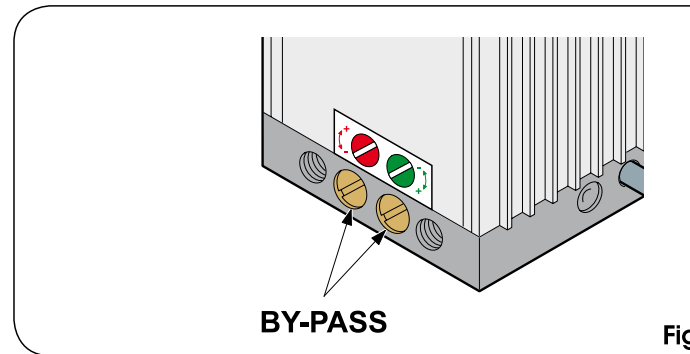
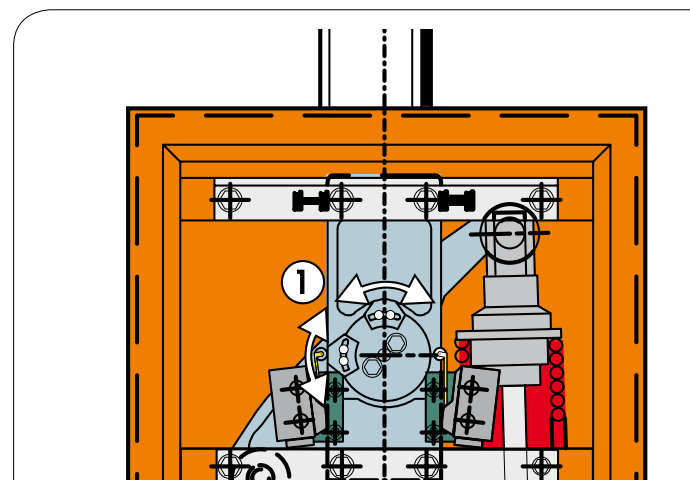

Fig. 13

5.3 ADJUSTING THE TRAVEL LIMIT SLOW DOWN

For beams with a length of over 4 m, we advise not to set too brief a slow down.

- 1) Adjust the cams of the travel limit device as shown in Fig. 12 ref. ① by loosening the two Allen screws. To increase the slow down angle, take the cam close to the relevant travel limit device. To reduce the slow down angle, take the cam far from the relevant travel limit device.
- 2) Set the slow down time of the control unit by adjusting the dedicated parameters.
- 3) Relock the system (see chap.6) and run a few operational tests to verify correct registration of the travel limit device, of spring balancing, and of the adjustment of transmitted force.





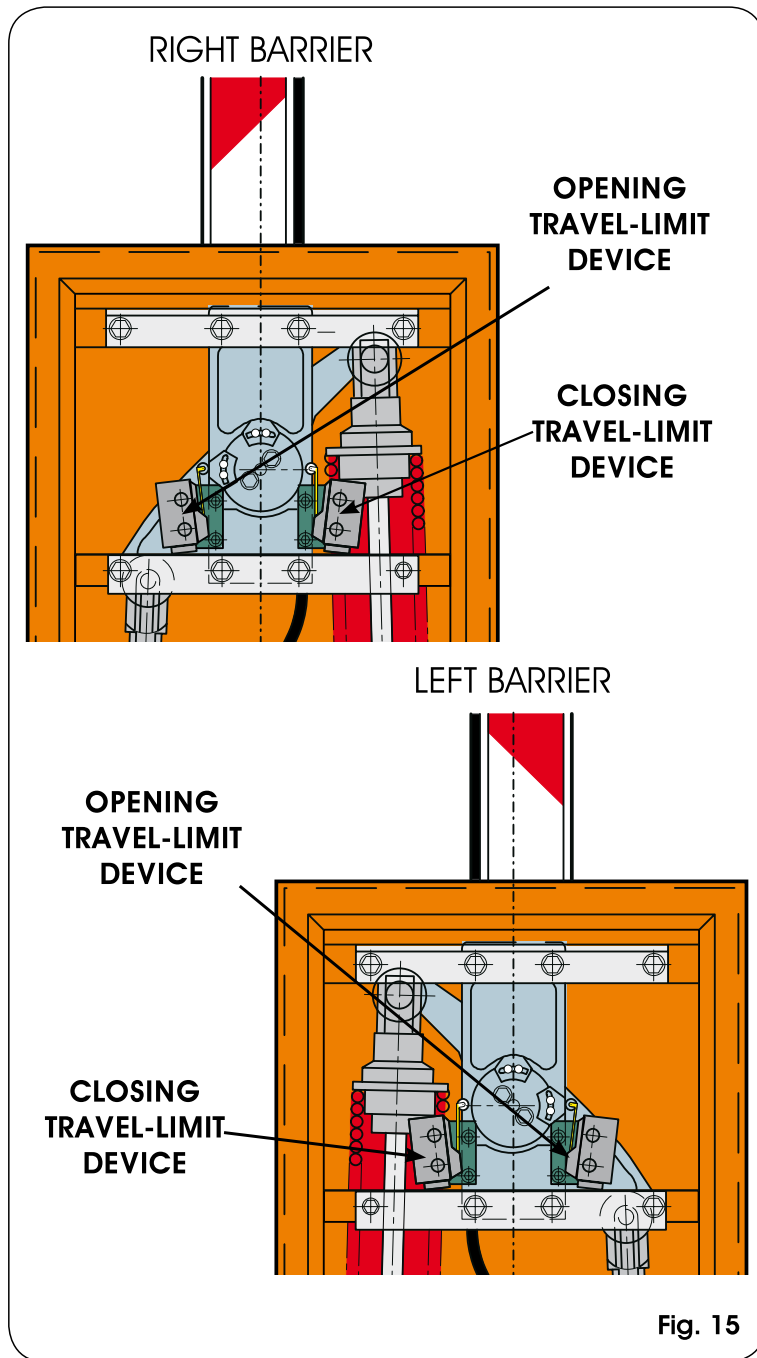
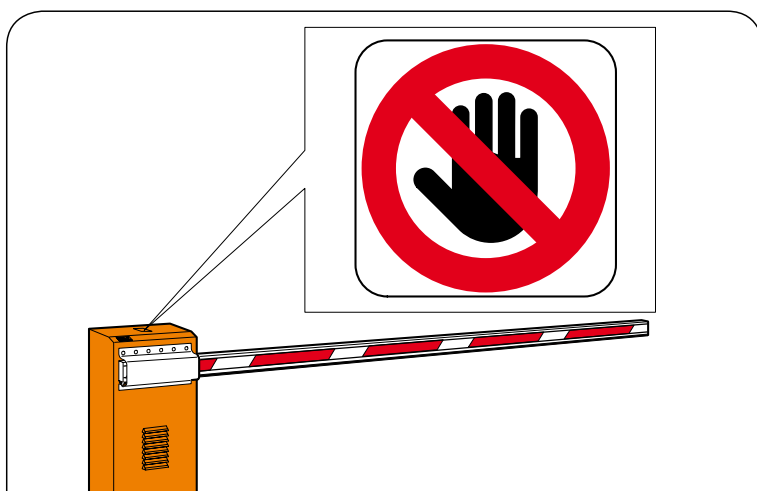

Fig. 15

#### 5.4 AUTOMATED SYSTEM TEST

After installation, apply the danger sticker on the top of the upright. Check operating efficiency of the automated system and all accessories connected to it.



Hand over the "User manual" to the customer, as the documentation required by current law illustrate the correct operation of the barrier, point out the potential danger zones.

#### 6 MANUAL MODE OPERATION

If the barrier has to be moved manually due to a power fault of the automated system, operate the release device with the supplied key.

The supplied release key can be triangular (Fig. 17 ref. ①) or customised (Fig. 17 ref. ② optional).

- Insert the release key in the lock and turn it **anti-clockwise** through one complete rev. as shown in Fig. 17.
- Open or close the barrier manually.

#### 7 RESTORING NORMAL OPERATION MODE

To prevent an involuntary pulse from activating the gate after the manoeuvre, cut power to the system before activating the locking system.

##### triangular release key (standard):

- turn the key **clockwise** until it stops and remove it (Fig. 17 ref. ①)

##### customised release key (optional):

- turn the key **clockwise** until the point where it can be removed (Fig. 17 ref. ②).

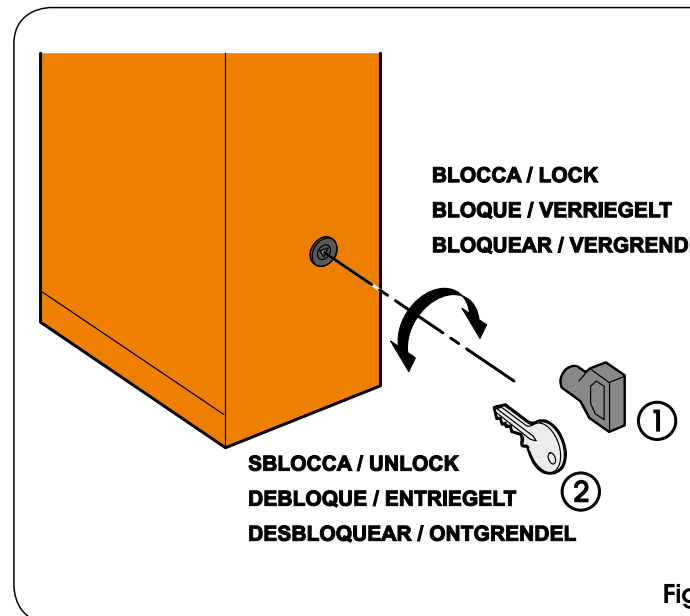

Fig. 16

#### 8 MAINTENANCE

Whenever doing 6-monthly maintenance, always check the settings of the by-pass screws, system balancing, and efficiency of safety devices.

##### 8.1 TOPPING UP OIL

Periodically check the quantity of oil inside the tank. An annual check is sufficient for low to medium use frequency; for heavier duty, check every 6 months. The level must not drop below the notch of the control panel (Fig. 18 ref. ①).

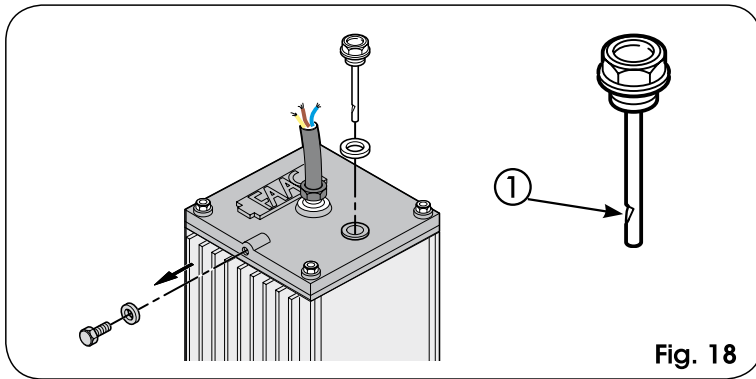

Fig. 18

### 8.2 BLEEDING OPERATION

If beam movement is incorrect, air must be bled from the hydraulic system.

Procedure:

- 1) Make sure that the bleed screw was eliminated (Fig.9)
- 2) Activate the beam electrically:
  - during opening, slightly loosen and re-screw the bleed screw of the piston with the balancing spring (Fig.1 ref. 33)
  - during closure, slightly loosen and re-screw the bleed screw of the piston without the balancing spring (Fig.1 ref.11).
- 3) If necessary, repeat the operation several times, until you obtain correct beam movement.

### 9 REPAIRS

For any repairs, contact FAAC's authorised Repair Centres.

### 10 CHANGING THE RH (LH) VERSION OF THE BARRIER INTO THE LH (RH) VERSION

Procedure for converting an RH (LH) version barrier into (RH) version:

1. Release the barrier as shown in Chap.6.
2. Position the beam in opening position and remove the rocker from the pocket as shown in Fig. 10 or Fig.11.
3. Re-lock the barrier as shown in Chap.7.
4. Screw the bleed screw on the control unit (Fig.9)
5. Fully loosen the spring adjustment ring-nut (ref.④).
6. Detach the feed pipes (Fig.19 ref.③ and ⑥) from the two pistons and plug the unions.
7. Remove the two pistons (Fig. 19 ref. ② and ⑤) from the upper and lower fittings and reverse their position, fit the rocker (Fig.18 ref. ①), against the opening travel mechanical stop.
8. Remove the pinion pocket and re-install it to suit the barrier at opening as in figure 19.
9. Fit the feed pipes as shown in Fig. 19, according to the configuration of the barrier (RH or LH).
10. Reverse the travel limit connectors on the control unit.
11. Remove the bleed screw (Fig.9) and carry out the bleed operations as indicated in paragraph 8.2.
12. Check the balance of the spring as indicated in paragraph 4.4.

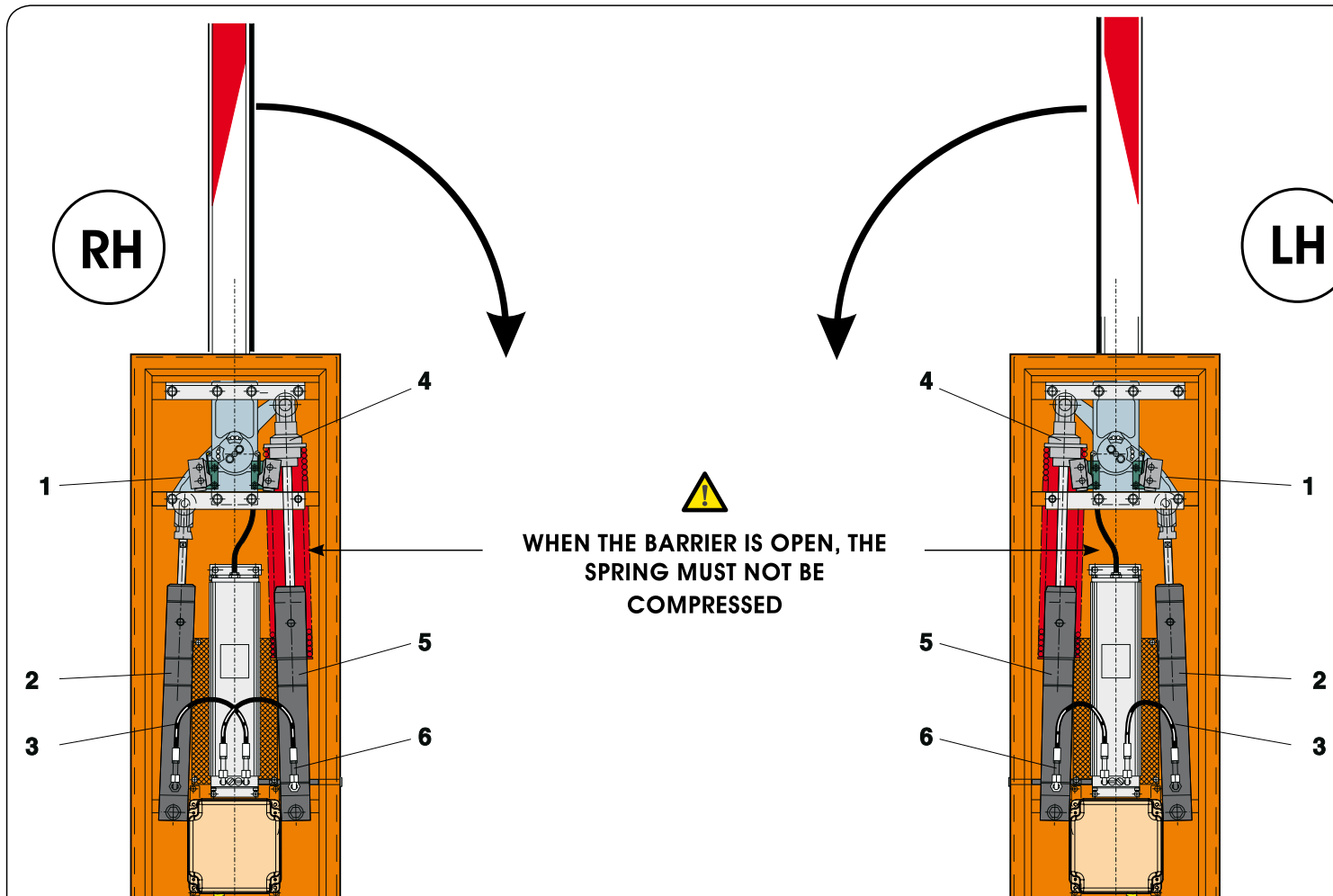

**11 AVAILABLE ACCESSORIES**

**ANTI-VANDAL VALVE (Fig. 20a)**

It protects the hydraulic system if the beam is forced.

**AUTOMATIC EMERGENCY RELEASE (Fig. 20b)**

During a power cut, the automatic emergency release allows you to manually lift the beam without accessing the release lever of the hydraulic control unit. A hydraulic system guarantees that the beam is stopped in opening position.

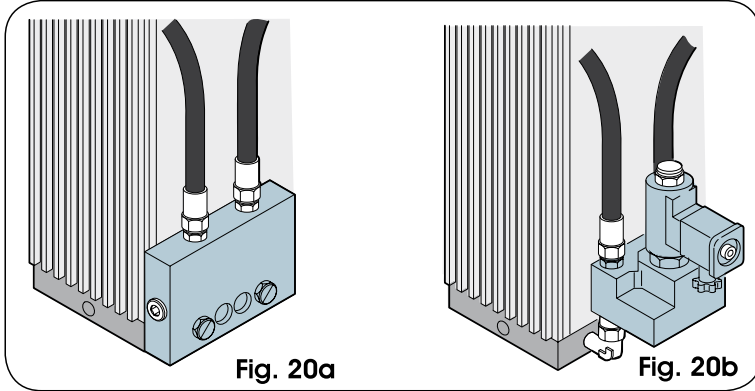

Fig. 20a

Fig. 20b

**SKIRT KIT**

The skirt kit increases visibility of the beam. It is available in lengths 2m and 3m.

**IMPORTANT: If a skirt kit is installed, the balancing spring must be adapted if possible.**

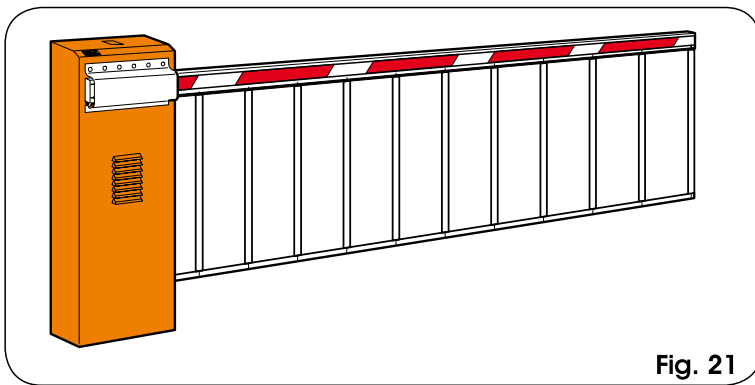

Fig. 21

**ARTICULATION KIT (mod. 620 only)**

The articulation kit makes it possible to articulate the rigid beam to a maximum ceiling height of 3.2 m.

**IMPORTANT: If the articulated kit is installed, the balancing spring must be adapted if possible.**

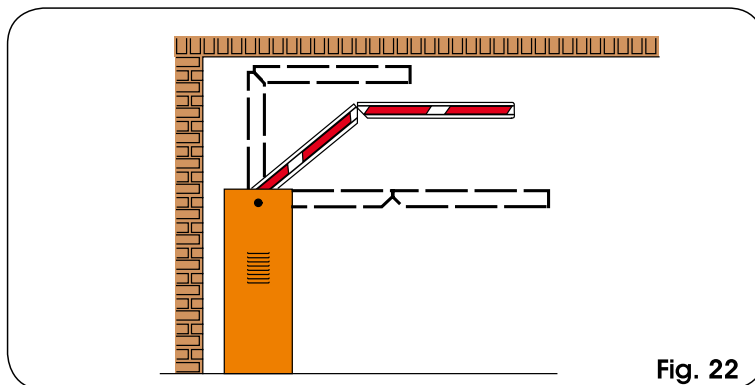

Fig. 22

**END FOOT**

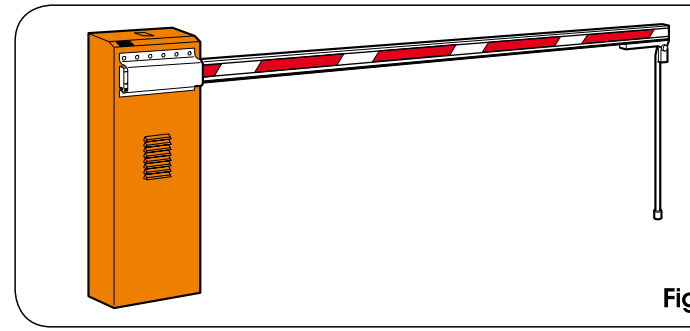

Fig.

**FORK SUPPORT**

The fork has two functions:

- it prevents the beam, when closed, from bending and if its end is stressed by extraneous forces.
- it allows the beam to rest when closed and thus prevents profile bending downward

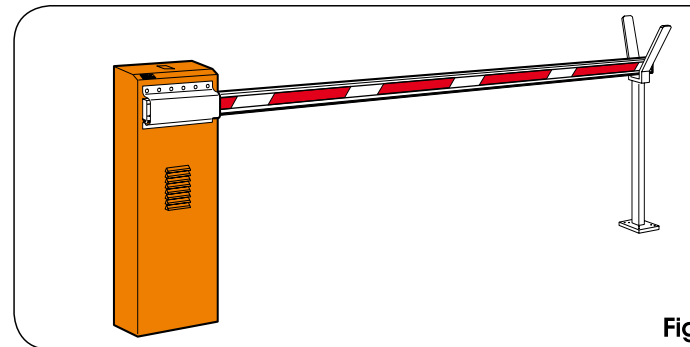
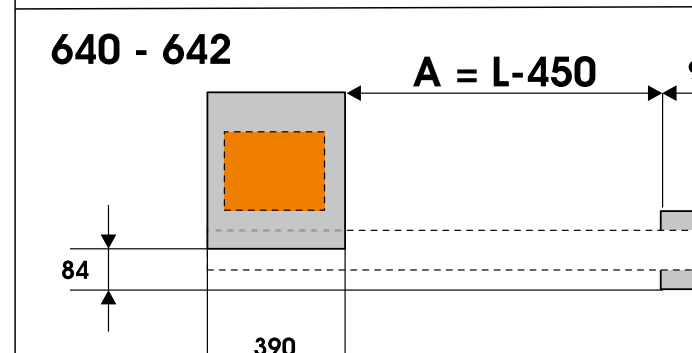
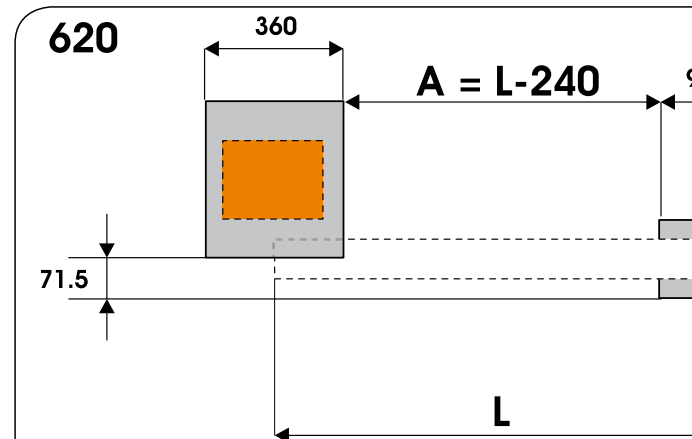

Fig.

To position the fork support foundation plate, refer to where:

- P1 = barrier foundation plate
- P2 = fork support foundation plate
- L = beam length (in mm)
- A = Distance between foundation plates

NB.: Dimensions are in mm.



Barrier model	Beam profile	Beam length (mm)	Pump flow-rate (l/min)	R.P.M.	Use frequency (%)	Indicative time of opening (sec)	Max. torque (Nm)
<b>620 STD</b>	620 RECTANGULAR STANDARD	1315 / 2555	1	1400	70	3,5	150
		2565 / 4815	0,75	1400	70	4,5	200
	620 RECT. + SKIRT	1815 / 2805	1	1400	70	3,5	150
		2815 / 4815	0,75	1400	70	4,5	200
	620 ROUND	1500 / 3240	1	1400	70	3,5	150
		3250 / 5000	0,75	1400	70	4,5	200
	620 ROUND PIVOTING.	1500 / 2740	1	1400	70	3,5	150
		2750 / 3000	0,75	1400	70	4,5	200
<b>620 STD ARTICULATED</b>	620 RECT. ARTICULATED A(*)=815/1314 mm.	1315 / 1815	1	1400	70	3,5	150
		1825 / 3815	0,75	1400	70	4,5	200
	620 RECT. ARTICULATED A(*)=1315/1814 mm.	1825 / 3815	0,75	1400	70	4,5	200
	620 RECT. ARTICULATED A(*)=1815/2075 mm.	1825 / 2815	0,75	1400	70	4,5	200
<b>620 R</b>	620 RECTANGULAR STANDARD	1315 / 2555	2	2800	100	2	80
		2565 / 3815	1,5	1400	100	3	100
	620 ROUND	1500 / 3240	2	2800	100	2	80
		3250 / 4000	1,5	1400	100	3	100
	620 ROUND PIVOTING.	1500 / 2740	2	2800	100	2	80
		2750 / 3000	1,5	1400	100	3	100
<b>620 R ARTICULATED</b>	620 RECT. ARTICULATED A(*)=815/1314 mm.	1315 / 2815	2	2800	100	2	80
	620 RECT. ARTICULATED A(*)=1315/1814 mm.	1825 / 2815	2	2800	100	2	80
	620 RECT. ARTICULATED A(*)=1815/2075 mm.	1825 / 2815	2	2800	100	2	80

Barrier model	Beam profile	Beam length (mm)	Pump flow-rate (l/min)	R.P.M.	Use frequency (%)	Indicative time of opening (sec)	Max. torque (Nm)
<b>640</b>	640 RECTANGULAR	3750 / 4240	2	2800	100	4	210
		4250 / 5240	1,5	1400	100	5.5	250
		5250 / 6740	1	1400	100	8	340
		6750 / 7000	1	1400	100	8	340
	640 RECT. + SKIRT	3750 / 4740	1	1400	100	8	340
		4750 / 5240	1	1400	100	8	340
		5250 / 5740	1	1400	100	8	340
	5750 / 7000	0,75	1400	100	8	470	
<b>642 STD/40</b>	620 RECTANGULAR	1315 / 2555	1	1400	70	3.5	150
		2565 / 3815	0,75	1400	70	4.5	200
	620 RECT. + SKIRT	1815 / 2805	1	1400	70	3.5	150
		2815 / 3815	0,75	1400	70	4,5	200
	620 ROUND	1500 / 3240	1	1400	70	3.5	150
		3250 / 4000	0,75	1400	70	4,5	200
	620 ROUND PIVOTING	1500 / 2740	1	1400	70	3.5	150
2750 / 3000		0,75	1400	70	4.5	200	
<b>642 R/40</b>	620 RECTANGULAR	1315 / 2555	2	2800	100	2	90
		2565 / 3815	1,5	1400	100	3	110
	620 ROUND	1500 / 3240	2	2800	100	2	90
		3250 / 4000	1,5	1400	100	3	110
	620 ROUND PIVOTING	1500 / 2240	1,5	1400	100	3	110
		2250 / 3000	2	2800	100	2	90
<b>642/70</b>	640 RECT.	3750 / 4240	2	2800	100	4	210
		4250 / 5240	1,5	1400	100	5.5	250
		5250 / 7000	1	1400	100	8	340
	640 RECT. + SKIRT	3750 / 5740	1	1400	100	8	340
		5750 / 7000	0,75	1400	100	8	470

# AUTOMATED SYSTEM 620 - 640 - 642 USER MANUAL

## 1 WARNINGS

- 1) FAAC declines all liability caused by improper use or use other than that for which the automated system was intended.
- 2) FAAC is not responsible for failure to observe Good Technique in the construction of the closing elements to be motorised, or for any deformation that may occur during use.
- 3) The automated system is supplied with an intrinsic anti-crushing safety device consisting of a torque control.
- 4) FAAC declines all liability as concerns safety and efficient operation of the automated system, if system components not produced by FAAC are used.
- 5) For maintenance, strictly use original parts by FAAC.
- 6) Do not in any way modify the components of the automated system.
- 7) The installer shall supply all information concerning manual operation of the system in case of an emergency, and shall hand over to the User the documentation provided by law.
- 8) Do not allow children or adults to stay near the product while it is operating.
- 9) Keep radiocontrols or other pulse generators away from children, to prevent the automated system from being activated involuntarily.
- 10) Transit is permitted only when the automated system is idle.
- 11) The User must not attempt any kind of repair or direct action whatever and contact qualified personnel only.
- 12) Maintenance: Check at least every 6 months the efficiency of the system, particularly the efficiency of the safety devices (including, where foreseen, the operator thrust force) and of the release devices.

## 2 DESCRIPTION

The automated system consists of a white beam in aluminium, with reflex reflectors and a steel upright. The operator is located inside the upright, and consists of a hydraulic control unit and two plunging pistons which, by means of a rocker, rotate the beam. The beam stays balanced thanks to a balancing spring assembled on one of the plunging pistons. The electronic control unit is also housed in the upright, inside a waterproof compartment.

The system is supplied with an adjustable anti-crushing safety device. It also includes a device stopping and locking the beam in any position, and a handy manual release for use in case of power cuts or faults.

**The 620 - 640 - 642 automated systems were designed and built to control vehicle access. Do not use for any other purpose.**

## 3 MANUAL MODE OPERATION

If the barrier has to be moved manually due to a power cut or fault of the automated system, operate the release device with the supplied key. The supplied release key can be triangular (Fig. 17 ref.①) or customised (Fig. 17 ref.② optional).

- Insert the release key in the lock and turn it **anti-clockwise** through one complete rev. as shown in Fig. 17.
- Open or close the beam manually.

## 4 RESTORING NORMAL OPERATION MODE

To prevent an involuntary pulse from activating the barrier during the manoeuvre, cut power to the system before activating the locking system.

### triangular release key (standard):

- turn the key **clockwise** until it stops and remove it (ref. ①)

### customised release key (optional):

- turn the key **clockwise** until the point where it can be removed (fig. 1 ref. ②).

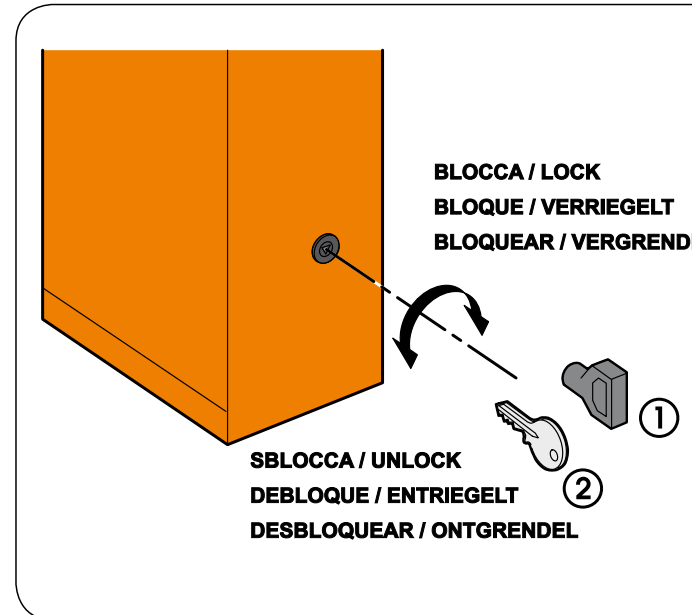

# MAINTENANCE REGISTER

## System data

aller	
omer	
f system	
al No.	
ion date	
rt-up	

## System configuration

PART	MODEL	SERIAL NUMBER
Operator		
Safety device 1		
Safety device 2		
of photocells 1		
of photocells 2		
ontrol device 1		
ontrol device 2		
adio control		
ashing lamp		

## n of residual risks and of foreseeable improper use

No.	Date	Job description	Signatures
<b>1</b>			Technician
			Customer
<b>2</b>			Technician
			Customer
<b>3</b>			Technician
			Customer
<b>4</b>			Technician
			Customer
<b>5</b>			Technician
			Customer
<b>6</b>			Technician
			Customer
<b>7</b>			Technician
			Customer
<b>8</b>			Technician
			Customer
<b>9</b>			Technician
			Customer
<b>10</b>			Technician
			Customer

Le descrizioni e le illustrazioni del presente manuale non sono impegnative. La FAAC si riserva il diritto, lasciando inalterate le caratteristiche essenziali dell'apparecchiatura, di apportare in qualunque momento e senza impegno ad aggiornare la presente pubblicazione, le modifiche che essa ritiene convenienti per miglioramenti tecnici o per qualsiasi altra esigenza di carattere costruttivo o commerciale.

The descriptions and illustrations contained in the present manual are not binding. FAAC reserves the right, while leaving the main features of the equipments unaltered, to undertake any modifications it holds necessary for either technical or commercial reasons, at any time and without revising the present publication.

Les descriptions et les illustrations du présent manuel sont fournies à titre indicatif. FAAC se réserve le droit d'apporter tout moment les modifications qu'elle jugera utiles sur ce produit tout en conservant les caractéristiques essentielles sans devoir pour autant mettre à jour cette publication.

Die Beschreibungen und Abbildungen in vorliegendem Handbuch sind unverbindlich. FAAC behält sich das Recht vor, ohne die wesentlichen Eigenschaften dieses Gerätes zu verändern und ohne Verbindlichkeiten in Bezug auf eine Neufassung der vorliegenden Anleitungen, technisch bzw. konstruktiv/kommerziell bedingte Verbesserungen vorzunehmen.

Las descripciones y las ilustraciones de este manual no comportan compromiso alguno. FAAC se reserva el derecho de dejando inmutadas las características esenciales de los aparatos, de aportar, en cualquier momento y sin comprometerse a poner al día la presente publicación, todas las modificaciones que considere oportunas para el perfeccionamiento técnico o para cualquier otro tipo de exigencia de carácter constructivo o comercial.

De beschrijvingen in deze handleiding zijn niet bindend. FAAC behoudt zich het recht voor op elk willekeurig moment veranderingen aan te brengen die het bedrijf nuttig acht met het oog op technische verbeteringen of alle mogelijke andere productie- of commerciële eisen, waarbij de fundamentele eigenschappen van de apparaat gehandhaafd blijven, zonder zich daardoor te verplichten deze publicatie bij te werken.

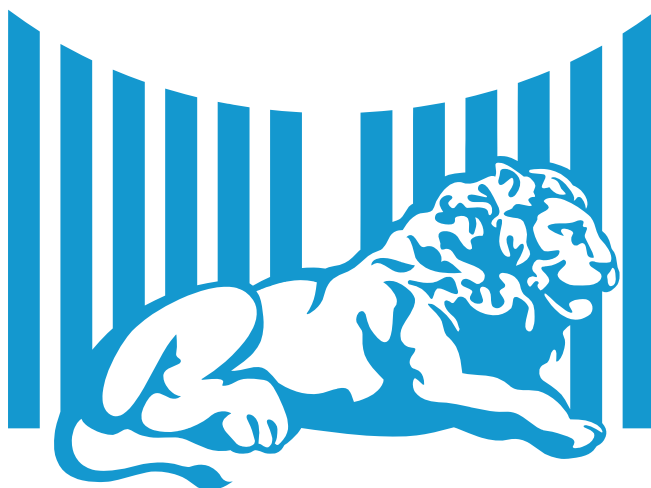

# FAAC

**FAAC S.p.A.**

Via Benini, 1

40069 Zola Predosa (BO) - ITALIA

Tel. 0039.051.61724 - Fax. 0039.051.758518

[www.faac.it](http://www.faac.it)

[www.faacgroup.com](http://www.faacgroup.com)

