

844 E R Z16
844 E R Z20

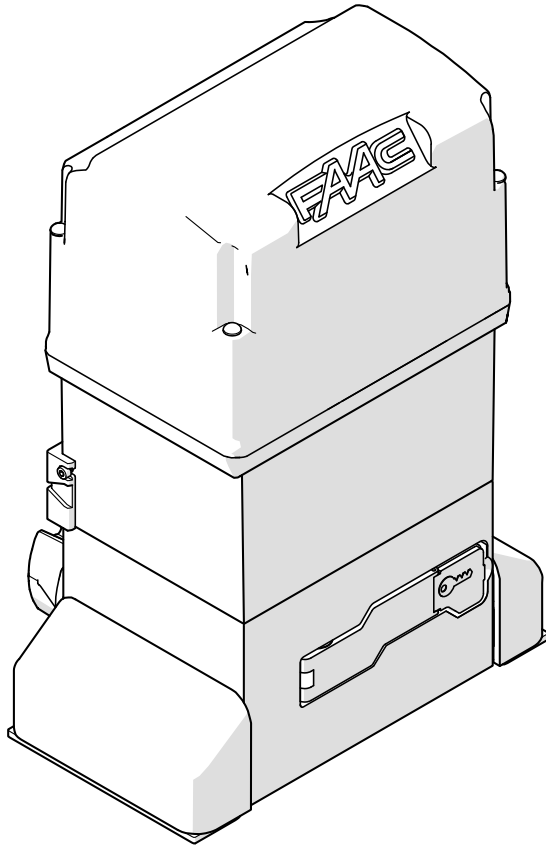

EAC

© Copyright FAAC S.p.A. dal 2018. Tutti i diritti riservati.

Nessuna parte di questo manuale può essere riprodotta, archiviata, distribuita né altrimenti copiata, in qualsiasi formato e con qualsiasi mezzo, sia esso elettronico o meccanico o tramite fotocopia, senza il preventivo consenso scritto di FAAC S.p.A. Tutti i nomi e i marchi citati sono di proprietà dei rispettivi fabbricanti. I clienti possono effettuare copie per esclusivo utilizzo proprio. Questo manuale è stato pubblicato nel 2018.

© Copyright FAAC S.p.A. from 2018. All rights reserved.

No part of this manual may be reproduced, archived, distributed to third parties or copied in any other way, in any format and with any means, be it electronic or by photocopying, without prior written authorisation by FAAC S.p.A. All names and trademarks mentioned are the property of their respective manufacturers. Customers may make copies exclusively for their own use. This manual was published in 2018.

© Copyright FAAC S.p.A. depuis 2018. Tous droits réservés.

Aucune partie de ce manuel ne peut être reproduite, archivée ou distribuée, ni copiée, sous tout format et avec tout moyen, qu'il soit électronique, mécanique ou par photocopie, sans le consentement écrit préalable de FAAC S.p.A. Tous les noms et les marques cités sont la propriété de leurs fabricants respectifs. Les clients peuvent faire des copies pour leur usage exclusif. Ce manuel a été publié en 2018.

© Copyright FAAC S.p.A. ab dem 2018. Alle Rechte vorbehalten.

Kein Teil dieses Handbuchs darf reproduziert, gespeichert, an Dritte weitergegeben oder sonst auf eine beliebige Art in einem beliebigen Format und mit beliebigen Mitteln kopiert werden, weder mit elektronischen, noch mechanischen Mitteln. Fotokopieren, ohne die Genehmigung von FAAC S.p.A. Alle erwähnten Namen und Marken sind Eigentum der jeweiligen Hersteller. Die Kunden dürfen nur für den Eigengebrauch Kopien anfertigen. Dieses Handbuch wurde 2018 veröffentlicht.

© Copyright FAAC S.p.A. del 2018. Todos los derechos están reservados.

No puede reproducirse, archivar, distribuirse a terceros ni copiarse de ninguna parte de este manual, con medios mecánicos o mediante fotocopia, sin el consentimiento escrito de FAAC S.p.A. Todos los nombres y las marcas citadas son de propiedad de los respectivos fabricantes. Los clientes pueden realizar copias para su uso exclusivo. Este manual se ha publicado en 2018.

© Copyright FAAC S.p.A. van 2018. Alle rechten voorbehouden.

Niets uit deze handleiding mag gereproduceerd, gearchiveerd, aan derden overgedragen of op andere wijze gekopieerd worden, in om het even welke vorm of met geen enkel middel, noch elektronisch, mechanisch of via fotokopie. Het kopiëren, zonder schriftelijke toestemming vooraf van FAAC S.p.A.



EU DECLARATION OF CONFORMITY

The Manufacturer

Company name: FAAC S.p.A. Soc. Unipersonale
Address: Via Calari, 10 - 40069 Zola Predosa BOLOGNA - ITALY

hereby declares on his sole responsibility that the following products:

Description: Gearmotor for sliding gates
Models: 844 E R Z16, 844 E R Z20

comply with the following applicable EU legislations:

2014/30/EU
 2011/65/EU

Furthermore, the following harmonised standards have been applied:

EN61000-6-2:2005
 EN61000-6-3:2007 + A1:2011

Bologna, Italy, 01-04-2018

CEO

A. Marcellan

DECLARATION OF INCORPORATION FOR PARTLY COMPLETED MACHINERY

(2006/42/EC ANNEX II P.1, B)

Manufacturer and person authorised to prepare the relevant technical documents

Company name: FAAC S.p.A. Soc. Unipersonale

Address: Via Calari, 10 - 40069 Zola Predosa BOLOGNA - ITALY

hereby declares that for the partly completed machinery:

Description: Gearmotors for sliding gates
Model: 844 E R Z16, 844 E R Z20

The essential requirements of the Machinery Directive 2006/42/EC (including all applicable amendments) that have been applied and fulfilled are as follows:

1.1.2, 1.1.3, 1.1.5, 1.2.1, 1.2.3, 1.2.5, 1.2.6, 1.3.1, 1.3.4, 1.3.6, 1.3.9, 1.4.1, 1.4.2.1, 1.5.1, 1.5.2, 1.5.5, 1.5.7, 1.5.8, 1.5.10, 1.5.11, 1.5.13, 1.6.1, 1.6.4, 1.7.2, 1.7.3, 1.7.4.2, 1.7.4.3

and that the relevant technical documentation has been compiled in accordance with part B of Annex VII.

Furthermore, the following harmonised standards have been applied:

EN12100:2010
 EN13849-1:2015
 EN13849-2:2012

Other standards applied:

EN 12453:2017

And also undertakes to transmit, in response to a reasoned request by the national authorities, relevant information on the partly completed machinery by mail or electronically.

Finally, the manufacturer declares that the above-mentioned partly completed machinery must not be put into service until the final machine in which it is incorporated has been declared compliant with the requirements of the mentioned Machinery Directive 2006/42/EC.

Bologna, Italy, 01-04-2018

CEO

A. Marcellan



CONTENTS

EU Declaration of conformity 3
 Declaration of incorporation for partly completed machinery ... 3

1. INTRODUCTION TO THIS INSTRUCTION MANUAL 5
 1.1 Meaning of the symbols used 5

2. SAFETY RECOMMENDATIONS 6
 2.1 Installer safety 6
 2.2 Transport and storage 6
 2.3 Unpacking and handling 7
 Vent closure 7
 2.4 Disposal of the product 7

3. 844 E R 8
 3.1 Intended use 8
 3.2 Limitations of use 8
 3.3 Unauthorised use 8
 3.4 Emergency use 8
 3.5 Product identification 9
 Product warnings 9
 3.6 Technical specifications 9
 3.7 Component identification 10
 Components supplied 10
 Components supplied separately 10
 3.8 Dimensions 11
 3.9 Manual operation 11
 Releasing the gearmotor 11
 Restoring operation 11

4. INSTALLATION REQUIREMENTS 12
 4.1 Mechanical requirements 12
 4.2 Electrical system 12
 4.3 Example system 13
 4.4 Installation dimensions 14

5. MECHANICAL INSTALLATION 15
 Tools required 15
 5.1 Replacing the spring (for leaves weighing more than 1000 kg) .. 15
 5.2 Installing the foundation plate 16
 5.3 Installing the gearmotor 17
 Open the vent hole 17
 5.4 Installing the rack 18
 Steel rack - Weld-on fastenings 18
 Steel rack - Screw-on fastenings 19
 Nylon rack 20
 5.5 Adjusting and checking 21
 5.6 Fastening the gearmotor permanently 21
 5.7 Installing the casing 22

6. OPTIONAL EQUIPMENT 22
 6.1 Release lock with personalised key 22

7. ELECTRONIC INSTALLATION 23
 7.1 Removing the cover from the board 23
 7.2 Board 780D 23
 Components 23
 Status LEDs 23
 7.3 Connections 24
 Motor 24

Magnetic limit stop sensor
 Control devices and accessories
 Radio receiver/decoder board
 Earthing the gearmotor
 Power cable
 7.4 Installing the cable glands
 7.5 Installing the board cover

8. START-UP
 Set-up procedure
 8.1 Installing the limit switches
 8.2 Programming the board
 Restoring factory settings
 8.3 Operating logics
 8.4 Adjusting the anti-crushing system
 Limiting the static force
 Obstacle detection
 Checks

9. PUTTING INTO SERVICE
 9.1 Final operations

10. ACCESSORIES
 10.1 Flashing light
 10.2 Photocells
 10.3 Sensitive edges
 10.4 LED/timed lamp, traffic light control, electric lock

11. DIAGNOSTICS
 11.1 Connection status
 11.2 Status of the automation
 11.3 Request assistance alert

12. MAINTENANCE
 12.1 Routine maintenance

13. INSTRUCTIONS FOR USE
 13.1 Safety recommendations
 13.2 Emergency use
 13.3 Manual operation
 Releasing the gearmotor
 Restoring operation

TABLES

☒ 1 Symbols: notes and warnings on the instructions ..
 ☒ 2 Symbols: safety signs and symbols (EN ISO 7010) ..
 ☒ 3 Symbols: personal protective equipment
 ☒ 4 Symbols: warnings on packaging.
 ☒ 5 Technical data (referring to 230 V~ 50 Hz/115 V~ 6
 ☒ 6 Symbols: tools
 ☒ 7 Board technical data
 ☒ 8 Basic programming
 ☒ 9 Advanced Programming
 ☒ 10 LEDs on the board
 ☒ 11 Status of the automation
 ☒ 12 Scheduled maintenance

1. INTRODUCTION TO THIS INSTRUCTION MANUAL

This manual provides the correct procedures and requirements for installing 844 E R and maintaining it in a safe condition.

When drafting the manual, the results of the risk assessment conducted by FAAC S.p.A. on the entire product life cycle have been taken into account in order to implement effective risk reduction measures. The following stages of the life cycle of the product have been considered:

- Delivery/handling
- Assembly and installation
- Set-up and commissioning
- Operation
- Maintenance/troubleshooting
- Disposal at the end of the product's life cycle

Risks arising from installation and using the product have been taken into consideration; these include:

- Risks for the installation/maintenance technician (technical personnel)
- Risks for the user of the automation system
- Risks to product integrity (damage)

In Europe, the automation of a gate falls under the Machinery Directive 2006/42/EC and the corresponding harmonised standards. Anyone automating a gate (new or existing) is classified as the Manufacturer of the Machine. They are therefore required by law, among other things, to carry out a risk analysis of the machine (automatic gate in its entirety) and take protective measures to fulfil the essential safety requirements specified in Annex I of the Machinery Directive.

FAAC S.p.A. recommends that you always comply with the EN 12453 standard and in particular that you adopt the safety criteria and devices indicated, without exception, including the dead-man function.

This manual also contains general information and guidelines, which are purely illustrative and not exhaustive, in order to facilitate the activities carried out by the Manufacturer of the Machine in all respects with regard to carrying out the risk analysis and drafting the instructions for use and maintenance of the machine. It should be clearly understood that FAAC S.p.A. accepts no liability for the reliability and/or completeness of the above instructions. As such, the manufacturer of the machine must carry out all the activities required by the Machinery Directive and the corresponding harmonised standards on the basis of the actual condition of the locations and structures where the product 844 E R will be installed, prior to commissioning the machine. These activities include the analysis of all the risks associated with the machine and subsequent implementation of all safety measures intended to fulfil the essential safety requirements.

This manual contains references to European standards. The automation of a gate must fully comply with any laws, standards and regulations applicable in the country where installation will take place.



Unless otherwise specified, the measurements provided in the instructions are in mm.

1.1 MEANING OF THE SYMBOLS USED

1 Symbols: notes and warnings on the instructions

WARNING ELECTRIC SHOCK HAZARD - The operation or step described must be carried out following the instructions provided and according to the regulations.

WARNING, personal injury hazard or risk of damage to components - The operation or step described must be carried out following the instructions provided and according to the safety regulations.

WARNING - Details and specifications which must be respected in order to ensure that the system operates correctly.

RECYCLING AND DISPOSAL - The materials used in manufacturing, the packaging and any electronic components must not be sent to landfill. They must be taken to authorised recycling and disposal centres.

FIGURE E.g. 1-3 see Figure 1 - item 3.

TABLE E.g. 1 see Table 1.

§ CHAPTER/SECTION E.g. §1.1 see Section 1.1.

● ○ STATUS OF THE LEDS ON THE BOARD

* ○ LED off ● LED on * LED flashing

2 Symbols: safety signs and symbols (EN ISO 7010)

GENERIC HAZARD
Personal injury hazard or risk of damage to components.

ELECTROCUTION HAZARD
Risk of electric shock from live parts.

CRUSHING HAZARD
Risk of crushing to the hands/feet due to the presence of heavy parts.

CUTTING/AMPUTATION/PUNCTURE HAZARD
Cutting hazard due to the presence of sharp components or use of pointed/sharp tools (drill).

SHEARING/TRAPPING HAZARD
Risk of fingers and hands being sheared or trapped by moving parts.

BURNING OR SCALDING HAZARD
Risk of burns due to the presence of high-temperature parts.

3 Symbols: personal protective equipment

Personal protective equipment must be worn to protect against hazards (e.g. cutting, shearing etc.):

Obligation to wear mask/goggles to protect the eyes from the risks due to the use of drill or welder.

Obligation to wear work gloves.

2. SAFETY RECOMMENDATIONS

This product is placed onto the market as “partly completed machinery”, therefore it cannot be commissioned until the machine in which it will be incorporated has been identified and declared to conform to the Machinery Directive 2006/42/EC by the actual Manufacturer.

-  Incorrect installation and/or incorrect use of the product might cause serious harm to people. Read and comply with all the instructions before starting any activity on the product. Keep these instructions for future reference. Perform installation and other activities adhering to the sequences provided in the instructions manual. Always comply with all the requirements contained in the instructions and warning tables at the beginning of the paragraphs. Always comply with the safety recommendations. Only the installer and/or maintenance technician is authorised to work on the automation components. Do not modify the original components in any way. Close off the work site (even temporarily) and prevent access/transit. EC countries must comply with the legislation that transposes the European Construction Site Directive 92/57/EC.

The installer is responsible for the installation/testing of the automation and for completing the Register of the system.







The installer must prove or declare to possess technical and professional proficiency to perform installation, testing and maintenance activities according to the requirements in these instructions.

2.1 INSTALLER SAFETY

Installation activities require special work conditions to reduce to the minimum the risks of accidents and serious damage. Furthermore, the suitable precautions must be taken to prevent risks of injury to persons or damage.

-  The installer must be in good physical and mental condition, aware of and responsible for the hazards that may be generated when using the product. The work area must be kept tidy and must not be left unattended. Do not wear clothes or accessories (scarves, bracelets, etc.) that may get caught in moving parts. Always wear the personal protective equipment recommended for the type of activity to be carried out. The required level of workplace lighting must be equal to at least 200 lux. Operate CE marked machinery and equipment in compliance with the manufacturer’s instructions. Use work instruments in good conditions. Use the transport and lifting equipment recommended in the instructions manual. Use safety-compliant portable ladders of adequate size, fitted with anti-slip devices at the top and bottom, equipped with retainer hooks.

2.2 TRANSPORT AND STORAGE

-  Follow the instructions on the package
-  4 Symbols: warnings on packaging.
-  Handle with care. Presence of fragile parts.
-  Up indication.
-  Keep away from water and moisture.
-  Maximum number of stacked packages.
-  CE marking.

PALLETISED SUPPLY

RISKS



PERSONAL PROTECTIVE EQUIPMENT

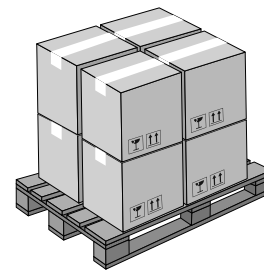
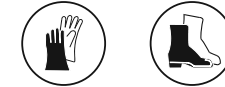

-  Follow the instructions on the package during handling. Use a forklift or pallet truck, following the applicable regulations to avoid the risk of collisions.



SINGLE PACKAGE

RISKS

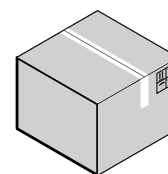
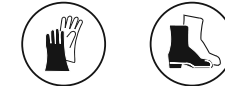

PERSONAL PROTECTIVE EQUIPMENT



-  Follow the instructions on the package during handling.
-  For manual lifting, there should be one person per 20 kg to be lifted.

STORAGE

Store the product in its original packaging, in closed and dry conditions, protected from the sun and free from dust and aggressive substances. Protect from mechanical stress. If stored for more than 12 months, regularly check the condition of the components and the

2.3 UNPACKING AND HANDLING

RISKS



PERSONAL PROTECTIVE EQUIPMENT



1. Open the package and remove the contents.
 - Do not lift the gearmotor by the casing or the electronic board. Grip the body of the gearmotor using the handholds A (1).
2. Check that all components are present and intact (See § Component identification).

The packaging materials (plastic, polystyrene etc.) must not be left within reach of children as they are potential sources of danger.

When you have finished with them, dispose of the packaging in the appropriate containers, as per applicable waste disposal regulations.

VENT CLOSURE

The 844 E R is supplied with the vent hole closed with a screw and washer (2). Whenever the gearmotor is handled, the vent must be closed to prevent oil leaking out.

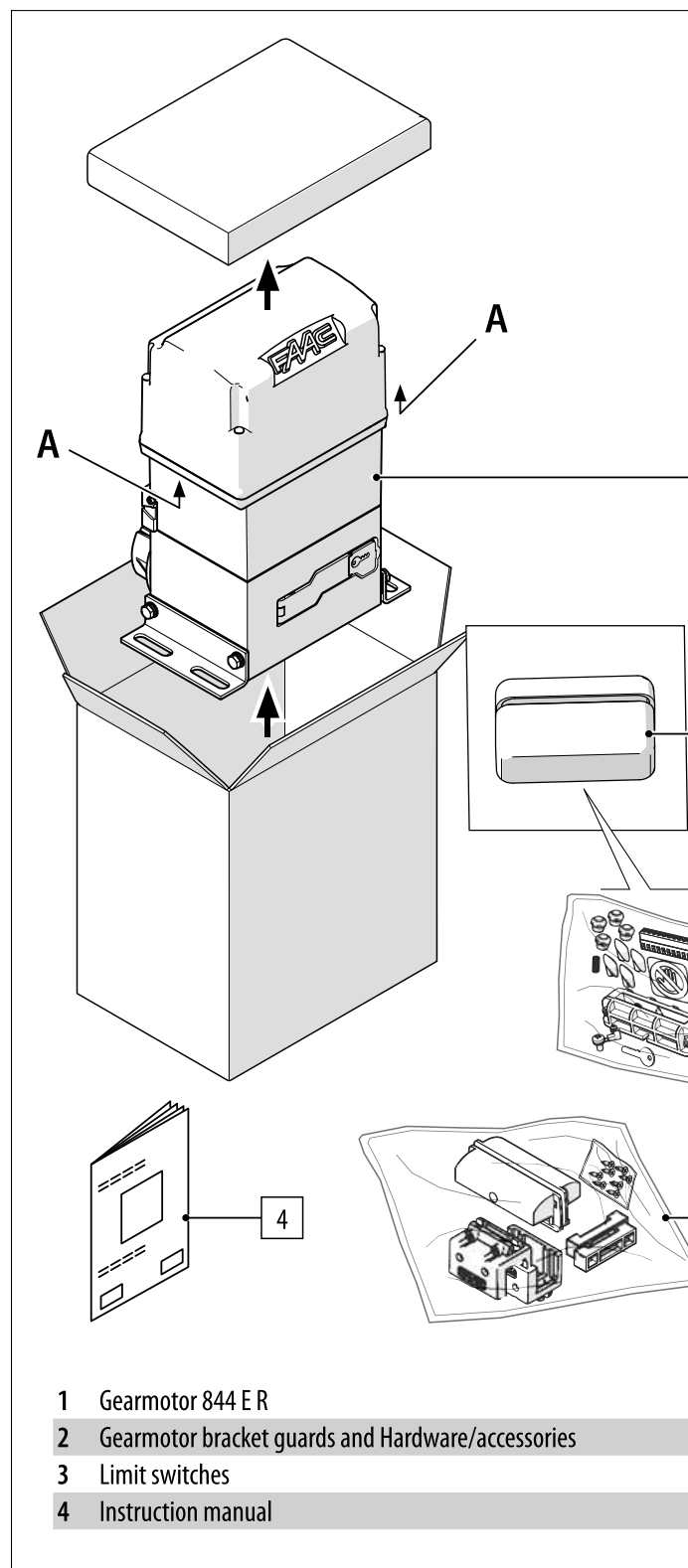

- 1 Gearmotor 844 E R
- 2 Gearmotor bracket guards and Hardware/accessories
- 3 Limit switches
- 4 Instruction manual

2.4 DISPOSAL OF THE PRODUCT

After having dismantled the product, dispose of it in compliance with the current waste disposal regulations.

Components and structural materials, batteries and electronic components must not be disposed of together with household waste. They must be taken to authorised disposal and recycling centres.

The oil must be gathered in a watertight container and given to an authorised disposal and recycling centre. Do not mix with other substances such as antifreeze or transmission fluids. Keep the used oil away from sources of heat and out of the children's reach. The fluid is not hazardous to health. In case of contact with eyes, skin or clothing, wash and rinse the affected parts. The technical data sheets of the fluids are available on request.

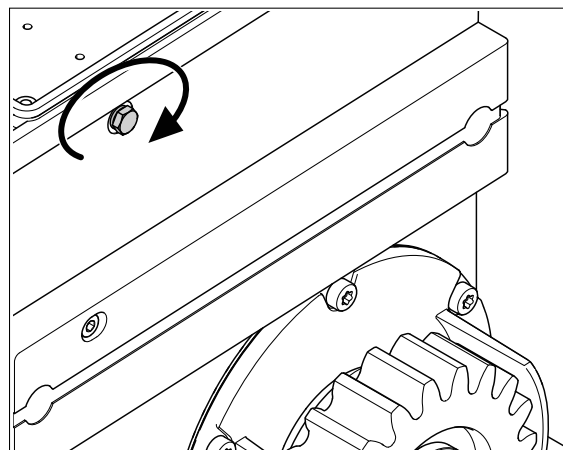

3. 844 E R

3.1 INTENDED USE

FAAC844 E R series gearmotors are designed to operate horizontal sliding gates for Apartment complexes, Offices/Industrial.

Only one gearmotor must be installed for each leaf. The system requires a special foundation plate, supplied separately, which is embedded in a plinth. The gate must be moved via a rack.

The 844 E R is intended for installation on gates in areas that are accessible by people, the main purpose of which is to provide access for goods, vehicles and people.

To move the gate manually, follow the instructions in section § Manual operation.



Any other use that is not expressly specified in these instructions is prohibited and could affect the integrity of the product and/or represent a source of danger.

3.2 LIMITATIONS OF USE

The maximum force required to move the leaf by hand over its entire length of travel must be 225 N for residential areas and 260 N for industrial or commercial areas.

The maximum force required to start the movement must be less than the maximum torque at initial thrust of the operator indicated in the technical data.

The leaf must fall within the dimensional and weight limits indicated in the technical data.

The presence of weather conditions such as snow, ice and strong wind, even occasional, could affect the correct operation of the automation, the integrity of the components and be a potential source of danger (see § Emergency use).

844 E R is not designed to be a security (break-in protection) system. If there is a pedestrian access gate integrated in the leaf of the gate, the motorised movement must be disabled when the pedestrian gate is not in a safe position.

The installation must be visible during the day and at night. If it is not, appropriate solutions must be provided to make the fixed and moving parts visible.

Implementing the automation requires the installation of the necessary safety devices, identified by the installer through an appropriate risk assessment of the installation site.

3.3 UNAUTHORISED USE

- Uses other than the intended use are prohibited.
- It is prohibited to install the automation system outside the limits specified in the Technical Data and Installation instructions sections.
- It is forbidden to use 844 E R in a constructional context other than the one provided by the manufacturer.
- No component part of the product may be modified.
- It is prohibited to install the automation system on escape doors.
- It is prohibited to install the automation system on escape doors.
- It is prohibited to install the automation system in environments in which there is a risk of explosion and/or fire: the presence of flammable gases or fumes is a serious safety hazard.
- It is prohibited to power the system with energy sources other than those specified.
- It is prohibited to integrate commercial systems or equipment other than those specified, or use them for purposes not intended and authorised by their respective manufacturers.
- Do not allow water jets of any type or size to come into contact with the gear motor.
- Do not expose the gear motor to corrosive chemical or spherical agents.
- It is prohibited to use and/or install accessories which have not been specifically approved by FAAC S.p.A.
- It is prohibited to use the automation system before proper commissioning.
- It is prohibited to use the automation system in the presence of faults which could compromise safety.
- It is prohibited to use the automation system with the fixed or mobile guards removed or altered.
- Do not use the automation system unless the area of operation is free of persons, animals or objects.
- Do not enter/remain in the area of operation of the automation system while it is moving.
- Do not try to prevent the movement of the automation system.
- Do not climb on, hold onto or let yourself be pulled by the leaf. Do not climb onto the gear motor.
- Do not allow children to approach or play in the area of operation of the automation system.
- Do not allow the control devices to be used by anyone who is not specifically authorised and trained to do so.
- Do not allow the control devices to be used by children or persons with mental and physical deficiencies unless they are supervised by an adult who is responsible for their safety.



During manual operation, gently guide the leaf the whole way, do not touch it and let it slide freely.

3.4 EMERGENCY USE

In emergencies or if there is a fault, turn off the power supply to the automation. If the leaf can be moved safely by hand, use the MANUAL OPERATION mode; otherwise place the automation out of service until it has been reset/repared.

3.5 PRODUCT IDENTIFICATION

The product can be identified by the plate (🔗3).

PRODUCT WARNINGS



The adhesive sign must be placed on the casing by the installer. It indicates the risk of trapping fingers / hands due to the rotation of the pinion.



Adhesive sign on the casing. It indicates the breather screw that must be removed before start-up.

3.6 TECHNICAL SPECIFICATIONS

Electromechanical oil-bath gearmotor, supplied with a pinion for the rack. Available in versions:

- 844 E R Z16 with pinion Z16
- 844 E R Z20 with pinion Z20

Irreversible system In order to be operated manually, the gearmotor has to be released using the special key.

Magnetic encoder The encoder determines the position of the leaf and the speed of movement.

Adjustable sensitivity obstacle detection The electronic board detects the presence of an obstacle via the encoder. If an obstacle is detected during opening or closing, the gate reverses for 1 s and then the automation stops.

Force limitation The maximum force exerted by the gearmotor is adjusted by means of the mechanical twin-disk clutch in oil-bath.

Magnetic limit switches To be fixed to the rack to set the opening and closing stop positions.

End of travel slowdown Adjustable electronic slowdown near to the open and closed positions.

Board 780D The built-in electronic board is equipped with a display, programming buttons and a protective plastic cover.

Equipment required The following must be purchased:

- foundation plate
- rack (module 4)

The image shows the identification plate and a diagram of the gearmotor assembly. The identification plate contains the following information:

- FAAC CE logo
- FAAC S.p.A. Soc. Unipersonale, Via Calati, 10 - 40069 Zola Predosa BOLOGNA Italy
- Made in Italy, Designed in Italy
- Cod. (Sale code)
- Mod. 844 E R Z16 (Product name)
- MMYY PROG (Month/year of production + Progressive for the month of production)
- V~ Hz W
- Nm IP
- FAAC HP OIL
- * REFERS TO 230 V ~ - 50Hz
- Barcode
- Cod. ... MMYY PROG (IDENTIFICATION NUMBER)

The diagram shows the gearmotor assembly with labels for the identification plate and the identification number.

Example: 0117 0001
made in: January 2017
progress: 000

🔗5 Technical data (referring to 230 V~ 50 Hz/115 V~ 60 Hz)

	844 E R Z16	844 E R Z20	844 E R Z16 [115 V]	844 E R Z20 [115 V]
Power supply voltage	220-240 V~ 50/60 Hz	220-240 V~ 50/60 Hz	115 V~ 50/60 Hz	115 V~ 50/60 Hz
Max power	660 W	660 W	660 W	660 W
Max thrust force	1160 N	930 N	1160 N	930 N
Max torque at initial thrust	625 N	500 N	625 N	500 N
Pinion	Z16 Module 4	Z20 Module 4	Z16 Module 4	Z20 Module 4
Start-up capacitor	12.5 µF V~	12.5 µF V~	70 µF V~	70 µF V~
Thermal protection	120°C automatic rearming	120 °C automatic rearming	120°C automatic rearming	120°C automatic rearming
Max leaf length	40 m	50 m	40 m	50 m
Max leaf weight	1800 kg	1000 kg	1800 kg	1000 kg
Leaf speed	9.5 m/min	12 m/min	9.5 m/min	12 m/min
Stopping space	40 mm	45 mm	40 mm	45 mm
Type of use	Apartment complexes, Offices / Industrial	Apartment complexes, Offices / Industrial	Apartment complexes, Offices / Industrial	Apartment complexes, Offices / Industrial
Ambient operating temperature	-20 °C to +55 °C	-20 °C +55 °C	-20 °C to +55 °C	-20 °C to +55 °C
Continuous use time (ROT)	70 min at 25°C 30 min at 55°C	70 min at 25°C 30 min at 55°C	70 min at 25°C 30 min at 55°C	70 min at 25°C 30 min at 55°C
Use frequency	70% at 25°C 50% at 55°C	70% at 25°C 50% at 55°C	70% at 25°C 50% at 55°C	70% at 25°C 50% at 55°C

3.7 COMPONENT IDENTIFICATION

COMPONENTS SUPPLIED

Gearmotor

- 1 Casing
- 2 Start-up capacitor
- 3 Transformer
- 4 Electronic board 780D with protective cover
- 5 Limit switch sensor
- 6 Pinion (Z16/Z20 Module 4) with hand guard
- 7 Anti-crushing clutch adjustment screw
- 8 Oil filler plug
- 9 Earth connector
- 10 Gearmotor body
- 11 Key release
- 12 Fastening brackets

Hardware/accessories

- 13 Gearmotor bracket guards
- 14 Cable glands to install in the board compartment
- 15 Casing fastening screws with screw caps, terminal boards, cable lug for earth cable and adhesive hazard warning sign, clutch adjustment spring (for leaves weighing more than 1000 kg)
- 16 Closing and opening magnetic limit switches (magnets, spacers, mounting hardware and screws)

COMPONENTS SUPPLIED SEPARATELY

The installation requires the following FAAC components that are supplied separately:

- 17 Steel rack with spacers (to be screwed or welded on)
or
 - 18 Nylon rack with mounting hardware - for leaves having a max weight of 400 kg
 - 19 Foundation plate with mounting hardware
- DANGER, AUTOMATIC MOVEMENT** warning sign

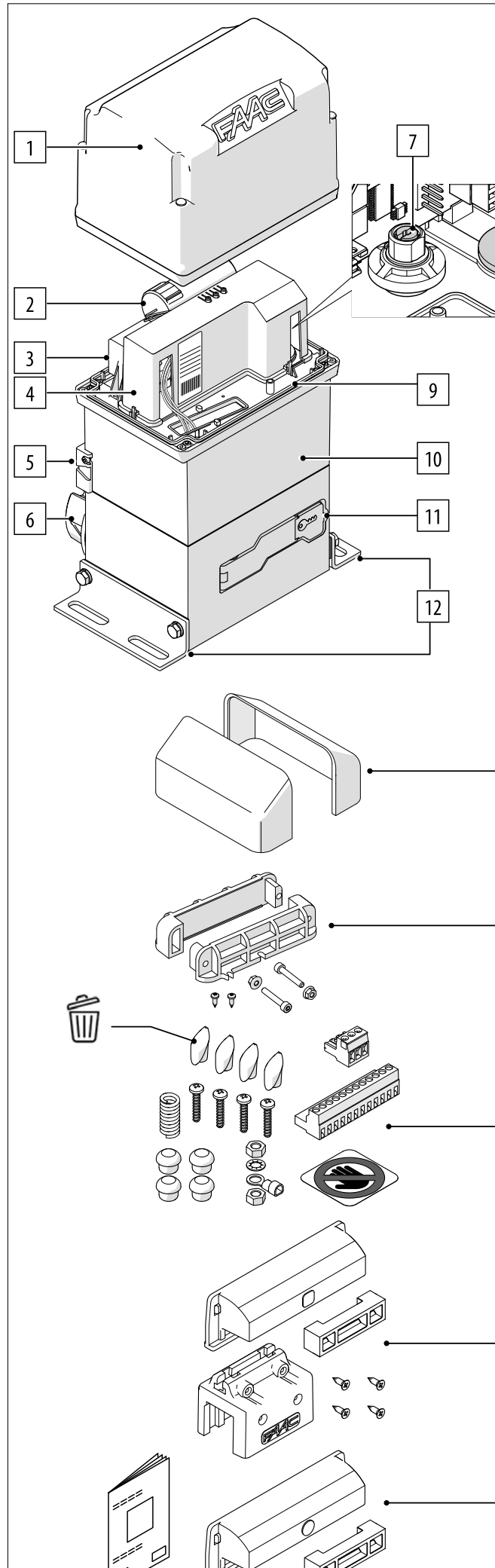
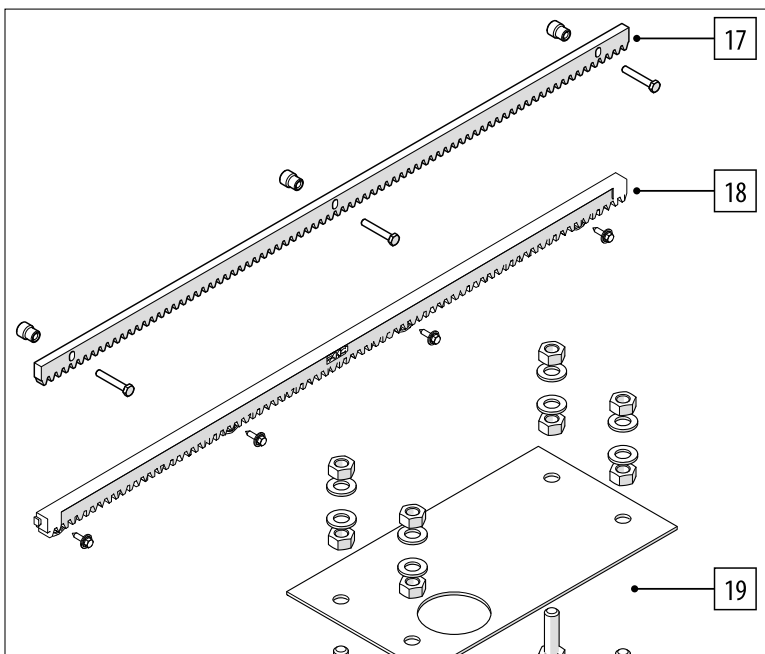

3.8 DIMENSIONS

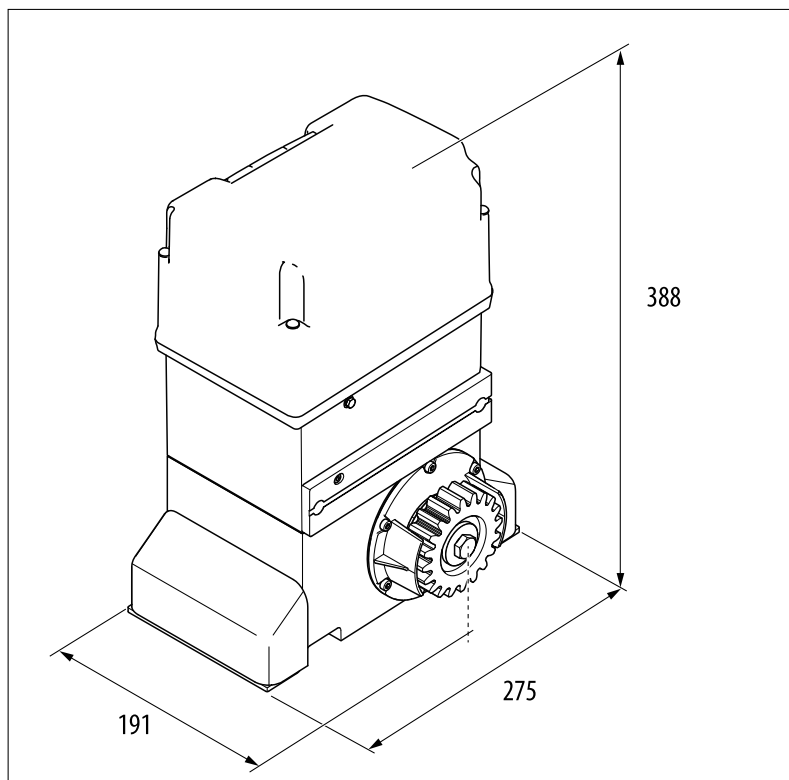

Centre distances

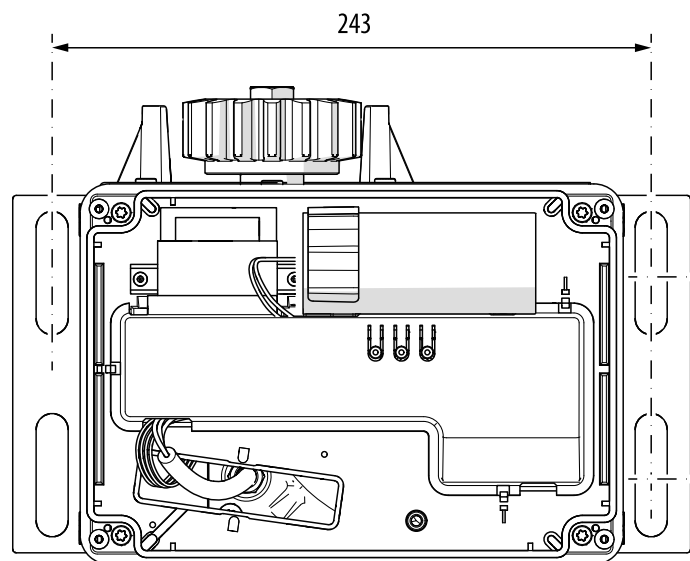

3.9 MANUAL OPERATION

In order to operate the leaf manually, the gearmotor has to be released using the key provided.

! Disconnect the power supply from the automation before releasing the gearmotor.

During manual operation, gently guide the leaf the whole way. Do not push it and let it slide freely.

Do not leave the gearmotor in the released mode: restore automatic operation after moving it manually.

RELEASING THE GEARMOTOR

1. Open the lock cover.
2. Insert the key and turn it clockwise by 90°.
3. Open the release lever by 90° (↻7).

RESTORING OPERATION

1. Close the release lever. Turn the key to the vertical position and remove it (↻7).
2. Close the lock cover.
3. Move the leaf manually to make sure that the mechanical system meshes correctly.

! Make sure that the gate is at its opening or closing end of travel position (the relative limit switch must be engaged) before turning the power back on and operating the automation.

Releasing the gearmotor

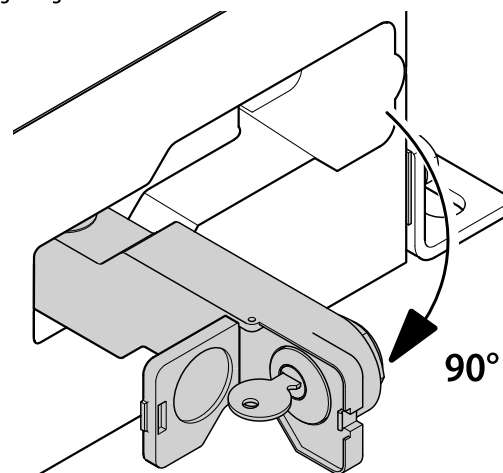

Restoring operation

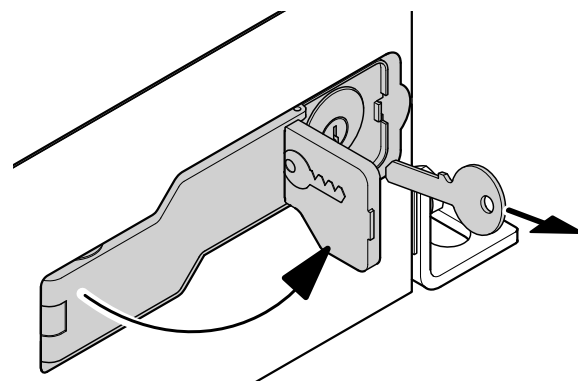

4. INSTALLATION REQUIREMENTS

4.1 MECHANICAL REQUIREMENTS

The mechanical structural components must comply with the requirements of EN 12604. Before installing the automation, the suitability of the mechanical requirements must be established and any work that is necessary in order to meet them carried out.

The essential mechanical requirements are as follows:



Solid ground to support the weight of the gate, the structures present and the gearmotor. Flat, horizontal paving in the area of movement of the leaf. There must be no chance of water accumulating in the installation area.

The structure (columns, guides, mechanical stops, leaf and counterweights) must be solid and there must be no risk of detachment or collapse (considering the weight of the leaf and the forces applied by the gearmotor and wind action). Perform structural calculations where necessary.

The structure must show no signs of corrosion or cracking.

The leaf must remain vertical throughout the entire length of travel, with a regular, smooth and uniform movement. The path along which the leaf slides must be perfectly horizontal (the leaf must not have a tendency to open or close spontaneously when it is released).

Appropriate devices must be installed to prevent the leaf from falling.

There should be a solid surface on the leaf sufficiently large to attach the rack to.

The sliding guides must be in good condition; they must be straight and not deformed, they must be fastened securely and there must be no obstacles along their entire length. The diameter of the guide wheels must be appropriate for the weight and length of the leaf and their profile section must coincide with that of the sliding guide. The number and position of the wheels must ensure an adequate and constant distribution of the weight.

A solid guide system for the suspended leaf in the case of a cantilever gate.

Presence of upper containing guide to prevent vertical oscillation of the leaf. The leaf must not under any circumstances come out from its guides and fall. Wheels, rollers and bearings in good condition, lubricated and free from play or friction.

Presence of external mechanical limit stops to limit the travel of the leaf when opening and closing. The stops must be suitably sized and solidly fastened so that they resist any impact of the leaf in the event of improper use (leaf pushed and left to slide freely). The mechanical limit stops must be positioned at 50 mm beyond the stop position of the leaf, and must ensure that the leaf remains inside its sliding guides.

The thresholds and protrusions of the paving must be appropriately shaped in order to prevent the risk of sliding or slipping.

For the creation of detection loops, refer to the specific instructions.

Presence of a safety area between the wall (or other fixed element) and the furthest protruding part of the open leaf, to protect against the risk of persons becoming trapped/crushed. Alternatively, check that the opening force required falls within the maximum permissible limits according to applicable standards and legislation.

Presence of safety areas between the fixed and moving parts, to protect against the risk of hands being trapped. Alternatively, apply protective elements that prevent fingers from being introduced.

Presence of a safety area between the paving and lower edge of the leaf, along its entire path, providing protection from the risk of feet becoming caught in and crushed beneath the wheels. Alternatively, apply protective elements preventing the introduction of feet.

No sharp edges or protruding parts should be present to ensure there are no cutting, hooking or perforation hazards. Alternatively, eliminate or protect any sharp edges and protruding parts.

No slots or openings should be present on the sliding leaf or the fencing to prevent the creation of a shearing hazard. Alternatively, apply protective mesh to any such openings. The mesh should be sufficiently fine to prevent introduction of body parts requiring protection, in relation to the distance

If the area of installation gives rise to the risk of impact by vehicle, install an appropriate protective structure to protect the gearmotor.

4.2 ELECTRICAL SYSTEM



Always shut off the power supply before performing any work. If a disconnect switch is not in view, apply a warning sign stating "Maintenance in Progress".



The electrical system must comply with applicable legislation in the country of installation.

Use components and materials with CE marking which are compliant with the Low Voltage Directive 2014/35/EU and EMC Directive 2014/30/EU.

The power supply line for the automation must be fitted with a main circuit breaker, with a suitable tripping threshold, a contact opening distance of at least 3 mm and a breaking capacity that complies with current legislation.

The power supply for the automation must be fitted with a 30 mA residual current switch.

The metal parts of the structure must be earthed.

Check that the protective earthing system complies with applicable regulations in the country of installation.

The electrical cables of the automation system must be of a size and class that is compliant with current legislation and laid in appropriate rigid or flexible conduits, either above or below ground.

Use separate conduits for the power supply and the 12-24 V control and accessories cables.

Check buried cable plans to ensure that there are no other electrical cables in proximity to the planned digging/drilling locations to prevent electrocution.

Check that there are no pipes in the vicinity as well.

The conduit fittings and the cable glands must prevent the entry of insects and small animals.

Protect extension connections using junction boxes with an IP 65 rating or higher.

It is recommended to install a flashing light in a visible position when it is moving.

For the creation of detection loops, refer to the relative instructions.

The control accessories must be positioned in areas that are always visible and not dangerous for the user. It is recommended to position the control accessories within the field of view of the automation. This is not the case of hold-to-run controls.

If an emergency stop button has been installed, it must be EN 13859-1.

Comply with the following heights from the ground:

- control accessories = minimum 150 cm
- emergency buttons = maximum 120 cm

If the manual controls are intended to be used by disabled or infirm persons, highlight them with suitable pictograms and make sure that they are easily accessible to all.

4.3 EXAMPLE SYSTEM

The example is an illustration only and is just one of the possible applications of the 844 E R (☑8).

1	Mains power supply	3G 1.5 mm ²
2	Circuit breaker	
3	Junction box	
4	Gearmotor 844 E R	
5	Photocell TX	
6	Photocell RX	
7	Key button	
8	Flashing light	
9	Mechanical stop	

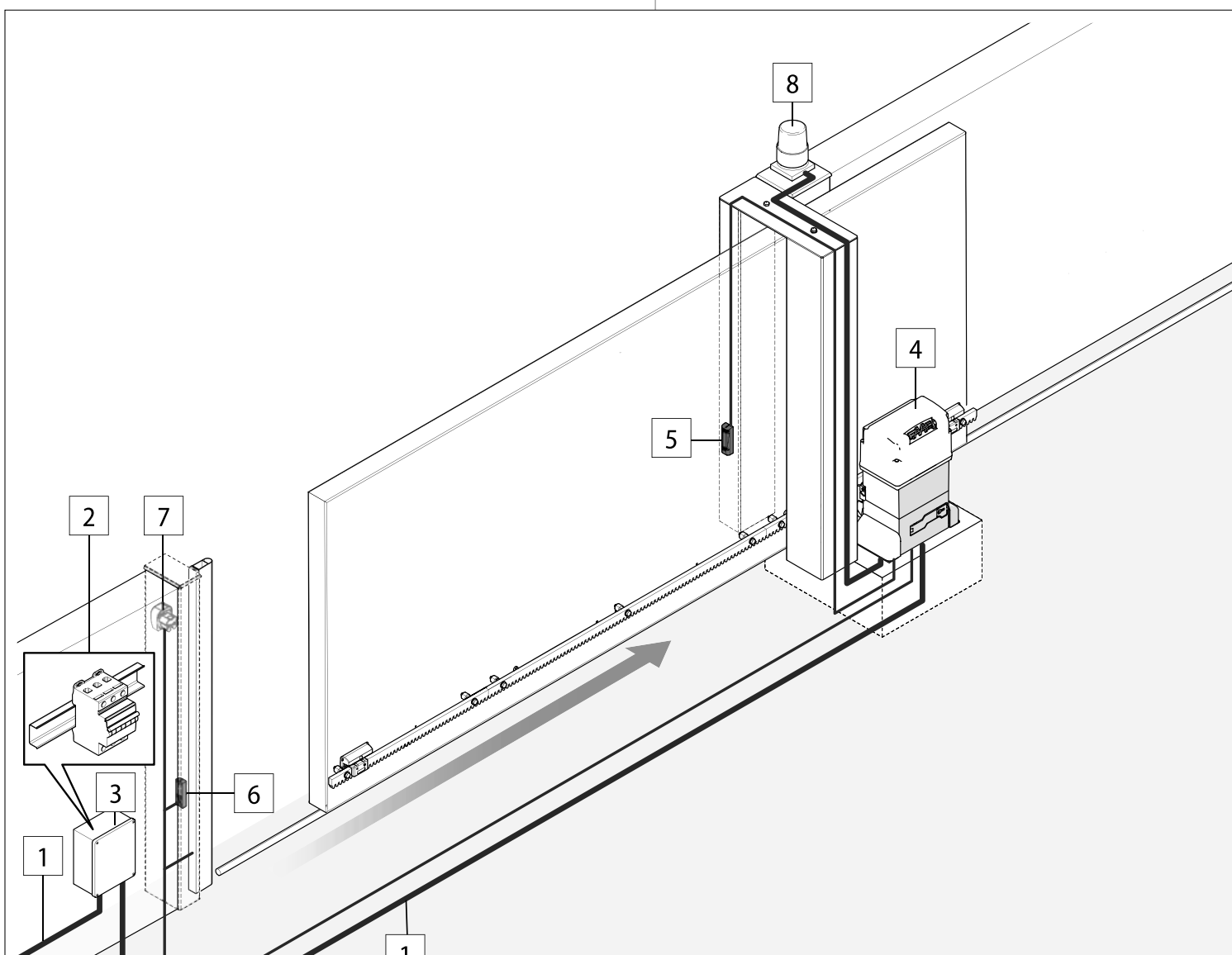

4.4 INSTALLATION DIMENSIONS

■ **FOUNDATION PLATE**

Opening to the left

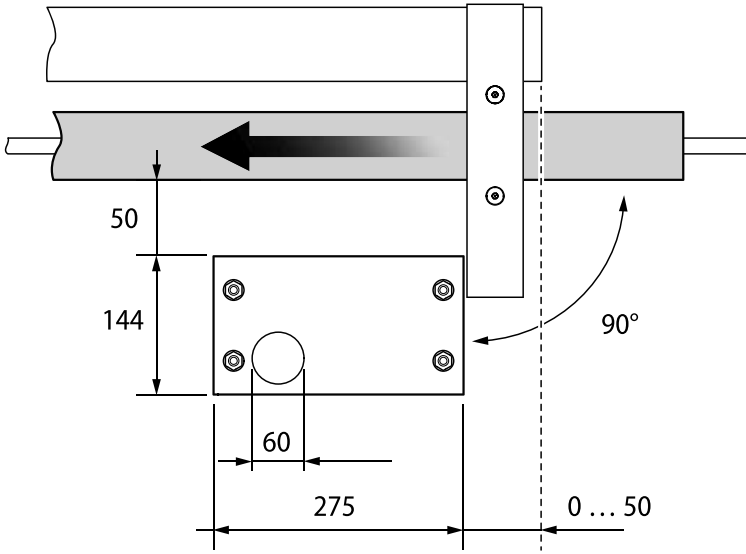

Opening to the right

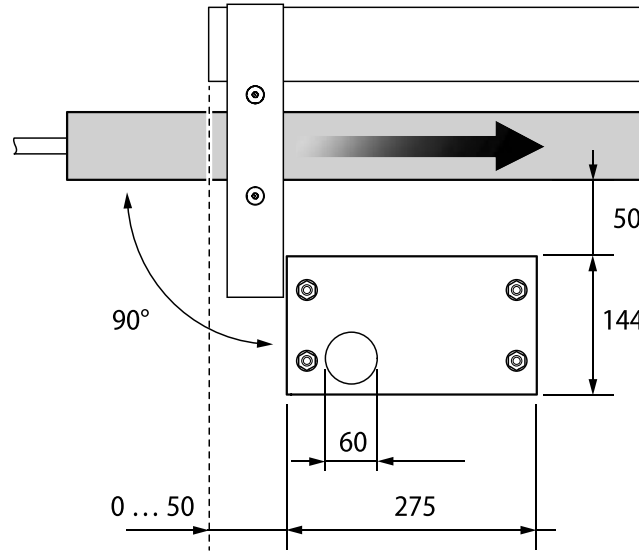

■ **RACK**

Steel rack

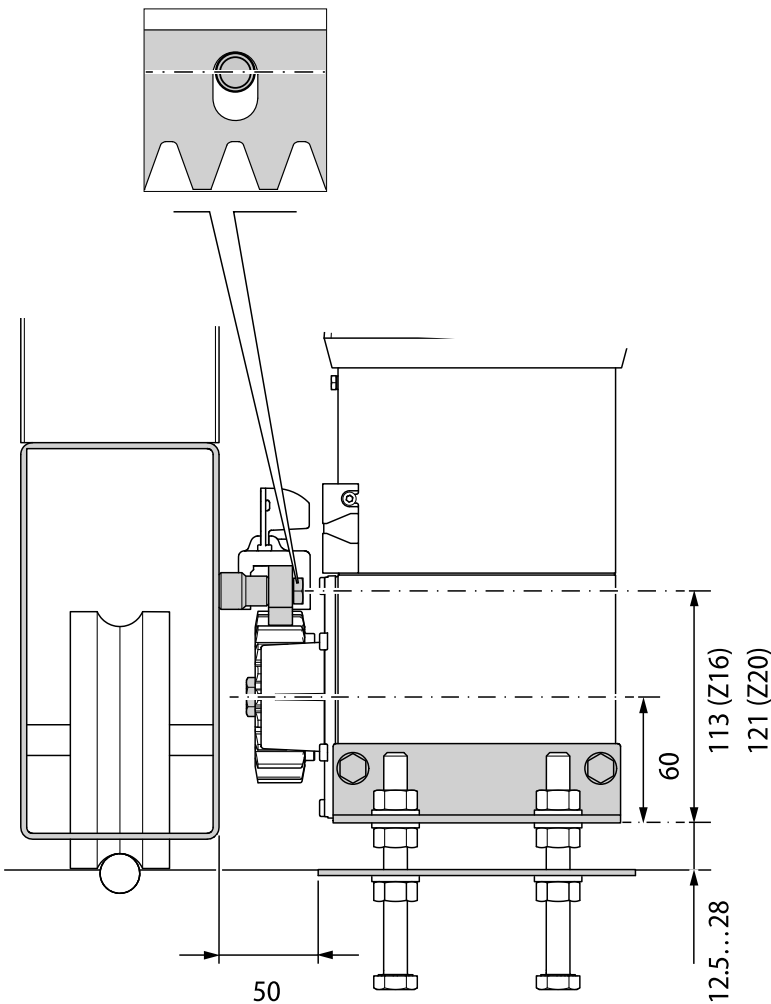

Nylon rack

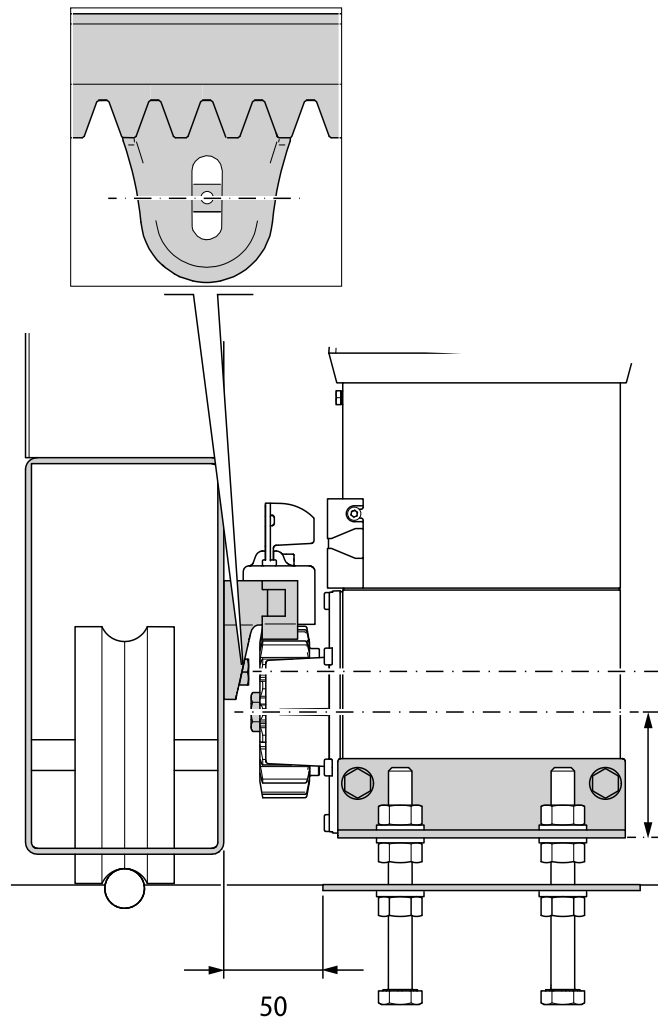

5. MECHANICAL INSTALLATION



The installation must comply with standard EN 12453. Mark off the work site and prohibit access/transit.

Installation must be carried out when it is not raining. In case of rain, a suitable shelter for the gearmotor must be provided until the mechanical and electronic installation has been completed.

Never handle the gearmotor by the electronic board.

TOOLS REQUIRED

The tools required are indicated below (☒ 6).



Use appropriate tools and equipment in working environments which with applicable legislation.

☒ 6 Symbols: tools

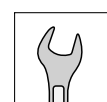

Spanner

7, 10, 13, 19

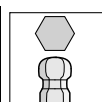

Hex key

3

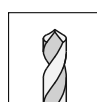

Drill bit for metal

5, 6.5

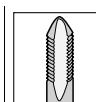

Threading tap
(for screw-on steel rack)

M8

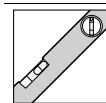

Level

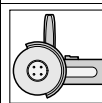

Angle grinder

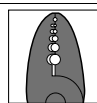

Wire strippers

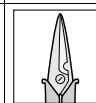

Electrician's scissors

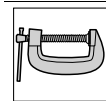

Screw clamp

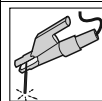

Welder
(for weld-on steel rack)

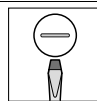

Flat-head screwdriver

2.5, 6

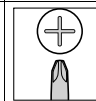

PHILLIPS SCREWDRIVERS

3, 8



x.x Nm

TORQUE WRENCH - if necessary for safety, a torque wrench and the TIGHTENING TORQUE will be specified

E.g.: SPANNER 7 set at 2.5 Nm



2.5 Nm

7

5.1 REPLACING THE SPRING (FOR LEAVES WEIGHING MORE THAN 1000 KG)

If the 844 E R is installed on a leaf that weighs more than 1000 kg, the clutch adjustment spring has to be replaced with the other spring supplied with the hardware/accessories (with a greater wire diameter and more resistant to compression).

With reference to ☒ 10 and ☒ 11, remove the screw whilst holding the drive shaft in position (turn the screw using a flat-head screwdriver or Allen key). Remove the spring and install the other spring. Replace the screw and tighten it to the maximum specified torque.



During the start-up phase, the anti-crushing system has to be adjusted.

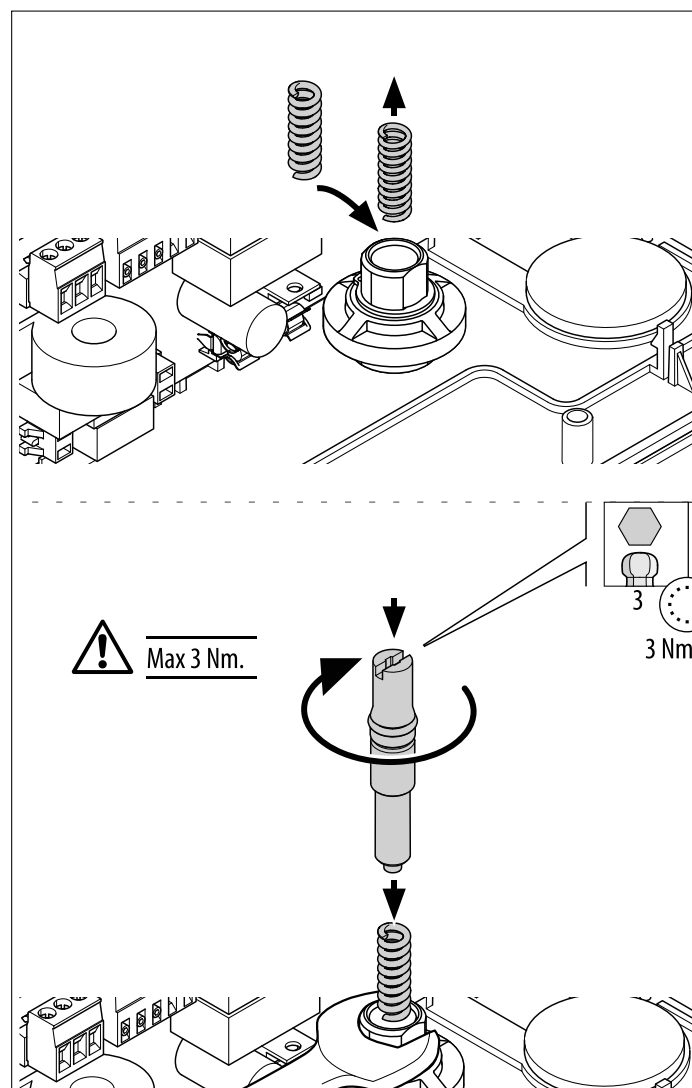
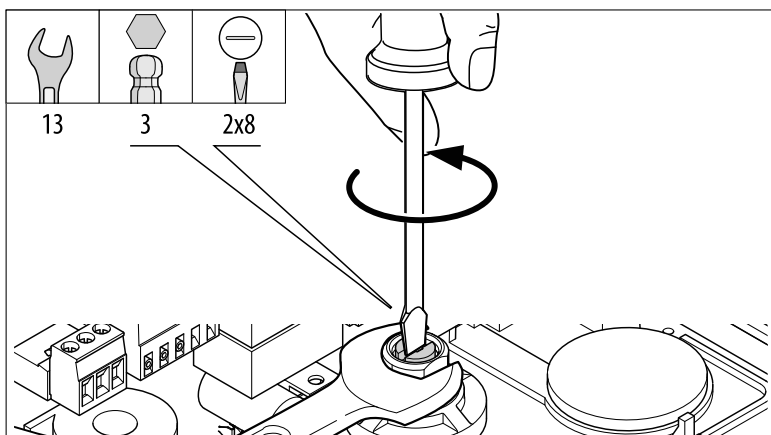

5.2 INSTALLING THE FOUNDATION PLATE

RISKS



PERSONAL PROTECTIVE EQUIPMENT



 Carry out the work with the power supply disconnected.

 - The 844 E R must be installed with the foundation plate.
 - The characteristics of the foundation, indicated in the schematic diagram in the appendix to this manual, are provided as a guideline only. The schematic considers the 844 E R applied within the maximum limits indicated in this manual and under the most arduous conditions. The installer is responsible for the evaluation of the foundation materials and dimensions on the basis of the characteristics of the ground and place of installation. Perform structural calculations where necessary.

1. Assemble the foundation plate (🔧12).
2. Make the hole in the ground. Fill it with concrete, making sure that the cable conduits protrude in the correct position with respect to the gearmotor. Place the plate at the centre of the foundation, leaving its surface uncovered (🔧13).
3. Clean any concrete from the surface of the plate and the nuts with washers so that they can be subsequently adjusted. Check the plate is horizontal using a spirit level.
4. Wait for the concrete to set.

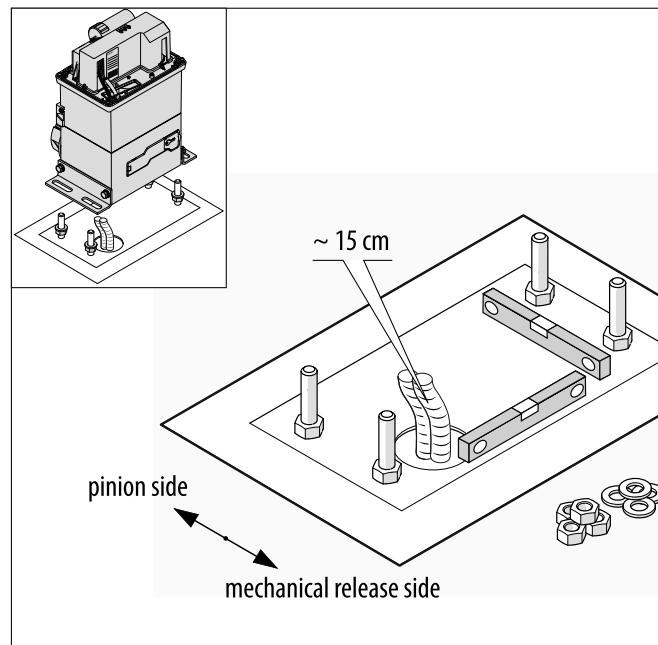
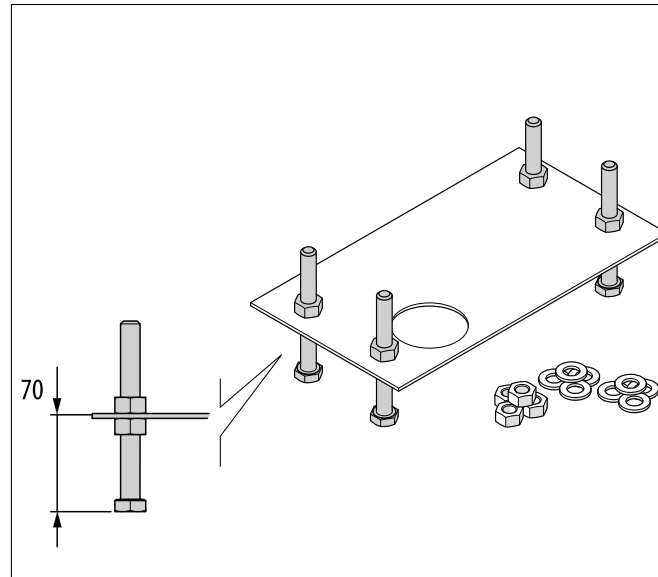

5.3 INSTALLING THE GEARMOTOR

RISKS



PERSONAL PROTECTIVE EQUIPMENT



Carry out the work with the power supply disconnected.

1. Make sure that the concrete of the plinth has set completely, then adjust all the support nuts to the height H indicated (14).
2. Place the washers on the nuts.
3. Remove the casing from the gearmotor. Position the gearmotor in correspondence with the 4 fasteners (15).
 - Pass the electric cables through the hole on the base and as far as the board.

Be careful not to damage the electrical cable tubes.

4. Make sure that the gearmotor is level. Position the washers and nuts (16).
 - Do not tighten the nuts so that the height can be adjusted when the rack is being installed.

OPEN THE VENT HOLE

Open the vent hole by removing the breather screw and washer (17).

A few drops of oil may leak out after the vent hole has been opened, even due to the initial movements.
Keep the screw and washer as they will have to be reinstalled if the gearmotor has to be removed and subsequently transported.

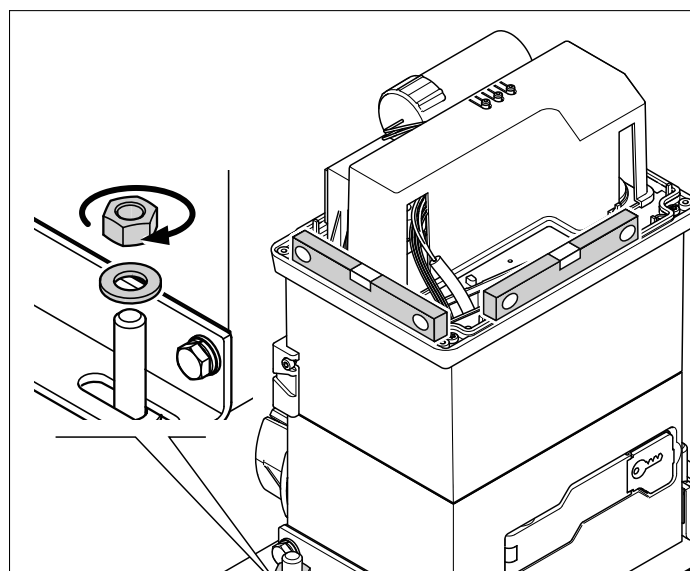
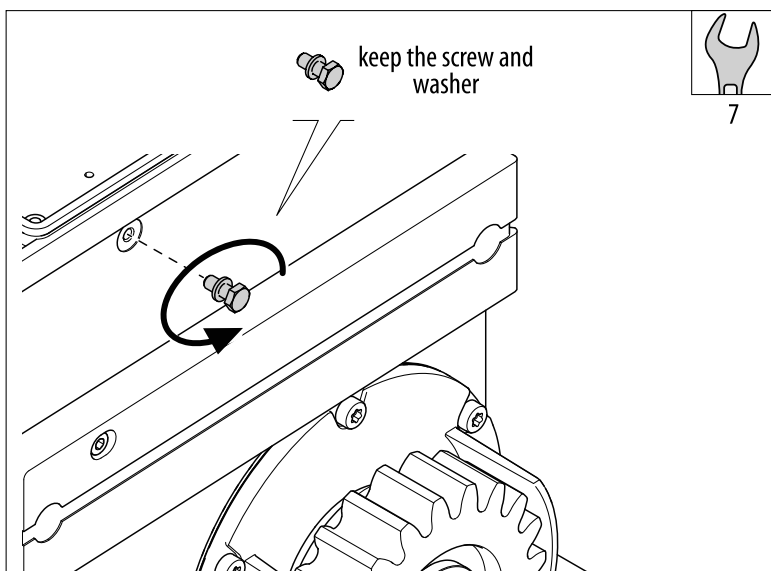
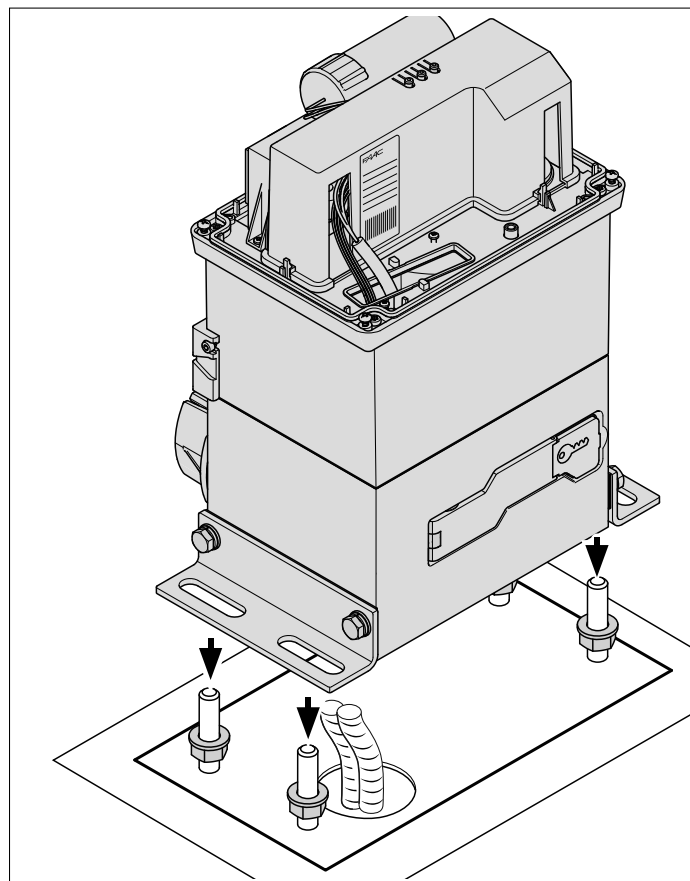
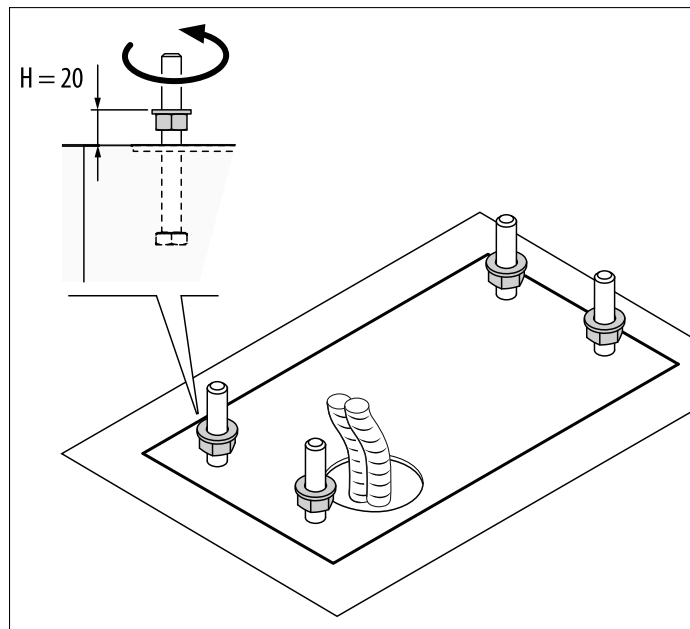

5.4 INSTALLING THE RACK

RISKS



PERSONAL PROTECTIVE EQUIPMENT



- DO NOT weld the spacers onto the racks.
- DO NOT weld the elements of the rack together.
- DO NOT apply grease or other lubricants to the racks.

Mounting the rack involves moving the leaf manually several times.

- Comply with the safety information S Manual operation.

STEEL RACK - WELD-ON FASTENINGS

- Welding must be carried out in a workmanlike manner. Safety may be affected if it is carried out badly.

- Rack thickness:
 - 8 mm for leaves weighing up to 400 kg max
 - 12 mm for leaves weighing more than 400 kg

1. Prepare all the elements of the rack that are required for the length of the leaf ():
 - screw 3 spacers onto each element of the rack
 - position the spacers so that they touch the top of the slots, this will allow future adjustments if the guide were to move downwards
 - if an element of the rack needs to be shortened, cut it with an angle grinder away from the slot.
2. Open the leaf manually.
3. Rest an element of the rack on the pinion. Make sure that it is level using a spirit level and secure it to the leaf using a screw clamp.
4. Weld the first spacer to the leaf () , then move the leaf with the rack resting on the pinion. Make sure that it is horizontal and weld on the other spacers.

- Protect the gearmotor from weld spatter. DO NOT connect the earth of the welder to the gearmotor.

5. Move the leaf. Rest the next element of the rack on the pinion so that it touches the previous element.
 - Line up the teeth by resting them on an element of the rack and assemble temporarily using screw clamps ().
6. Make sure that it is horizontal using a spirit level. Weld the spacers (as in step 4). Remove the screw clamps.
7. Repeat from step 5 for all elements of the rack.

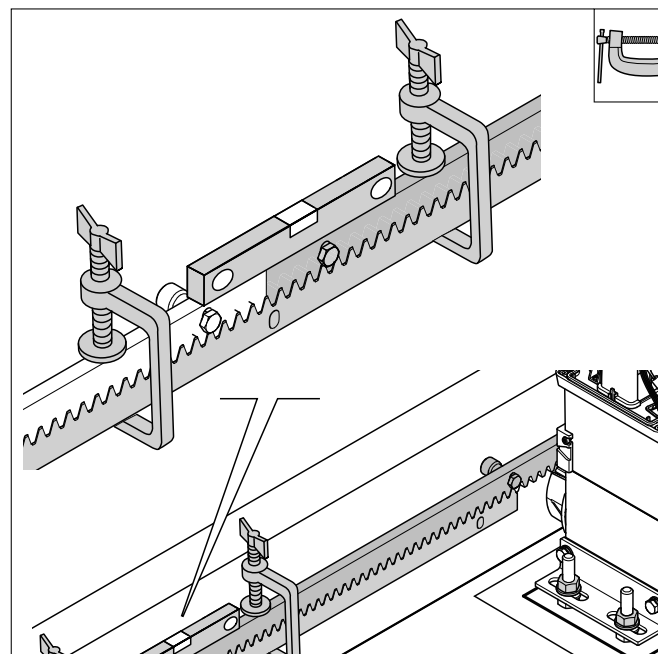
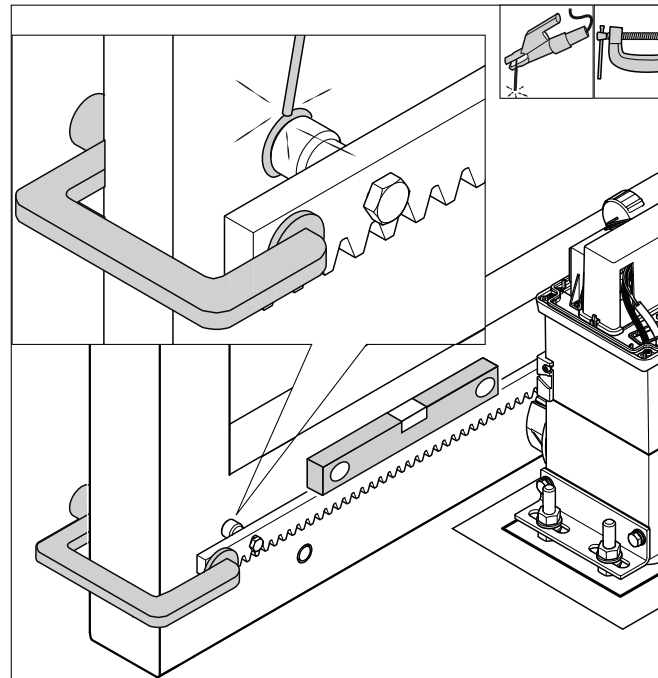
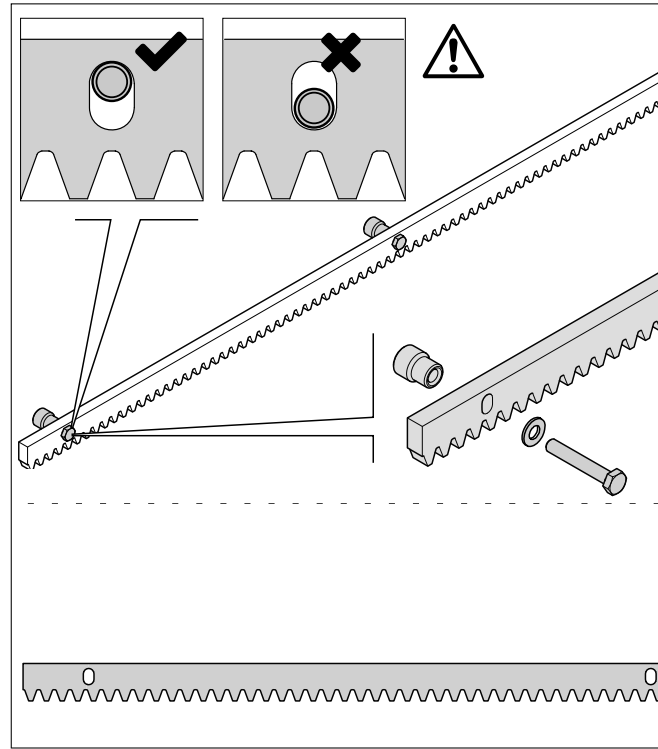

STEEL RACK - SCREW-ON FASTENINGS



Rack thickness:

8 mm for leaves weighing up to 400 kg max

12 mm for leaves weighing more than 400 kg

The rack installation accessories contain screws for aluminium or steel leaves. Use specific screws for other materials.

1. Open the leaf manually.
2. Rest an element of the rack on the pinion.
3. Place a spacer between the rack and the leaf. Make sure that it is horizontal using a spirit level. Mark the hole to be drilled on the leaf (🔗21).
 - Position the spacers so that they touch the top of the slots, this will allow future adjustments if the guide were to move downwards.
4. Drill the hole and make a thread in it (🔗22).
5. Fasten using the screw and washer (🔗23).
6. Move the leaf with the rack resting on the pinion. Repeat steps 3 ... 5 for the other fixing points.
7. Move the leaf. Rest the next element of the rack on the pinion so that it is touching the previous element.
 - Line up the teeth by resting them on an element of the rack and assemble temporarily using screw clamps (🔗24).
8. Repeat steps 3 ... 6 for the other fixing points. Remove the screw clamps.
9. Repeat from step 7 for all elements of the rack that are required for the length of the leaf.
 - If an element of the rack needs to be shortened, cut it with an angle grinder away from the slot.

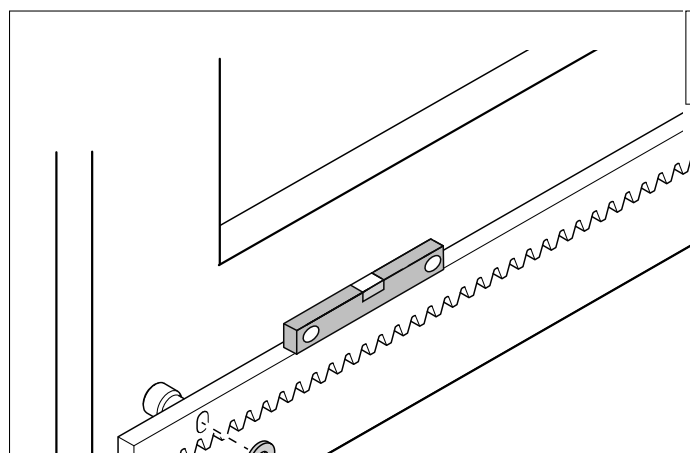
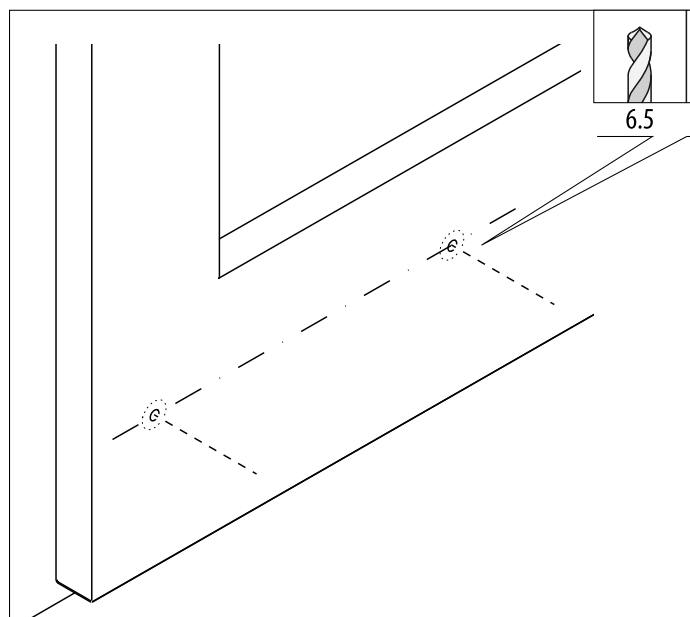
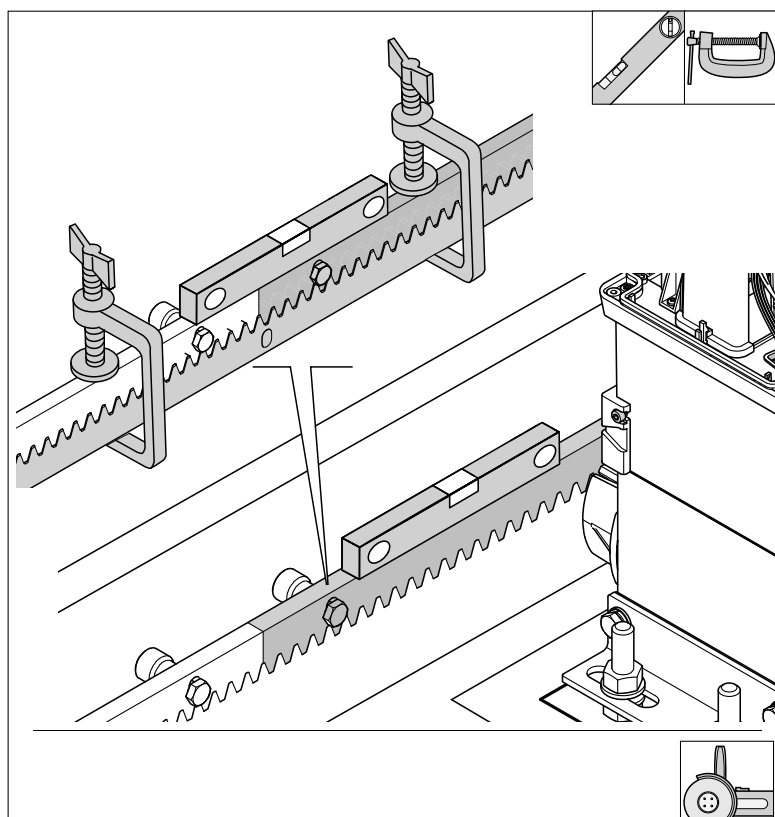
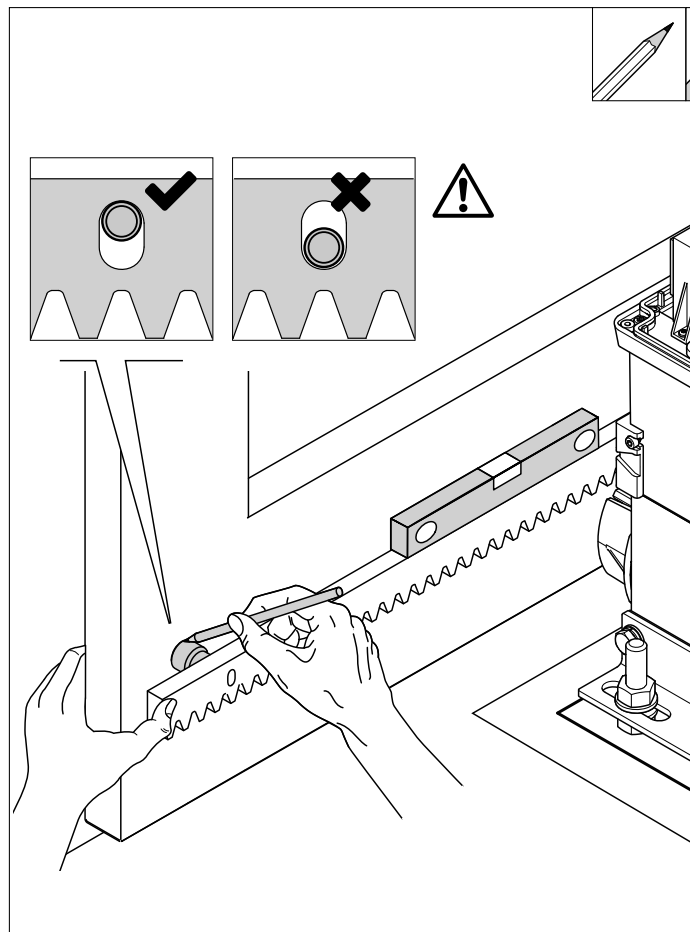

NYLON RACK

i Rack thickness: 20 mm for leaves weighing up to 400 kg max.

1. Close the leaf manually.
2. Rest an element of the rack on the pinion (25). Make sure that it is horizontal using a spirit level.
3. Drill holes at the centre of the slots (1). Fasten using suitable screws and washers.

! Use fixing screws that are specific for the material from which the leaf is made. Self-tapping screws and washers are available for aluminium or steel and should be ordered separately (2).

4. Move the leaf manually. Assemble the next interlocking element at the end of the previous one and rest it on the pinion (26). Make sure that it is horizontal using a spirit level.
5. Drill holes at the centre of the slots. Fasten using suitable screws and washers.
6. Repeat steps 4 and 5 for all elements of the rack that are required for the length of the leaf.
 - If an element needs to be shortened, cut it with an angle grinder away from the slot.

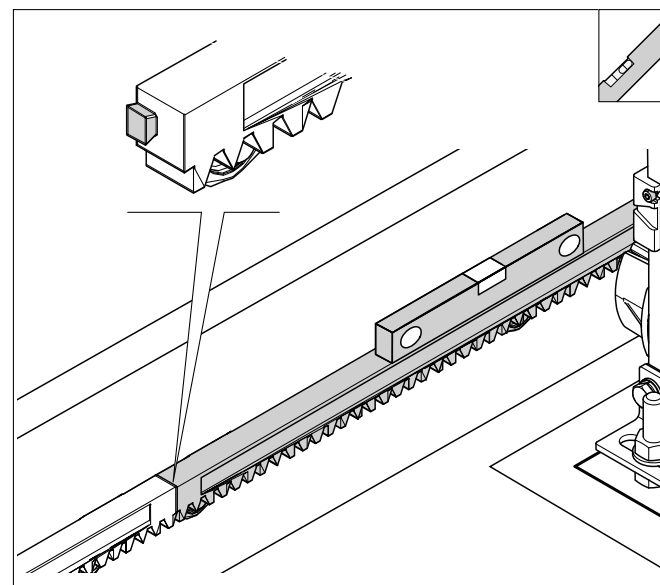
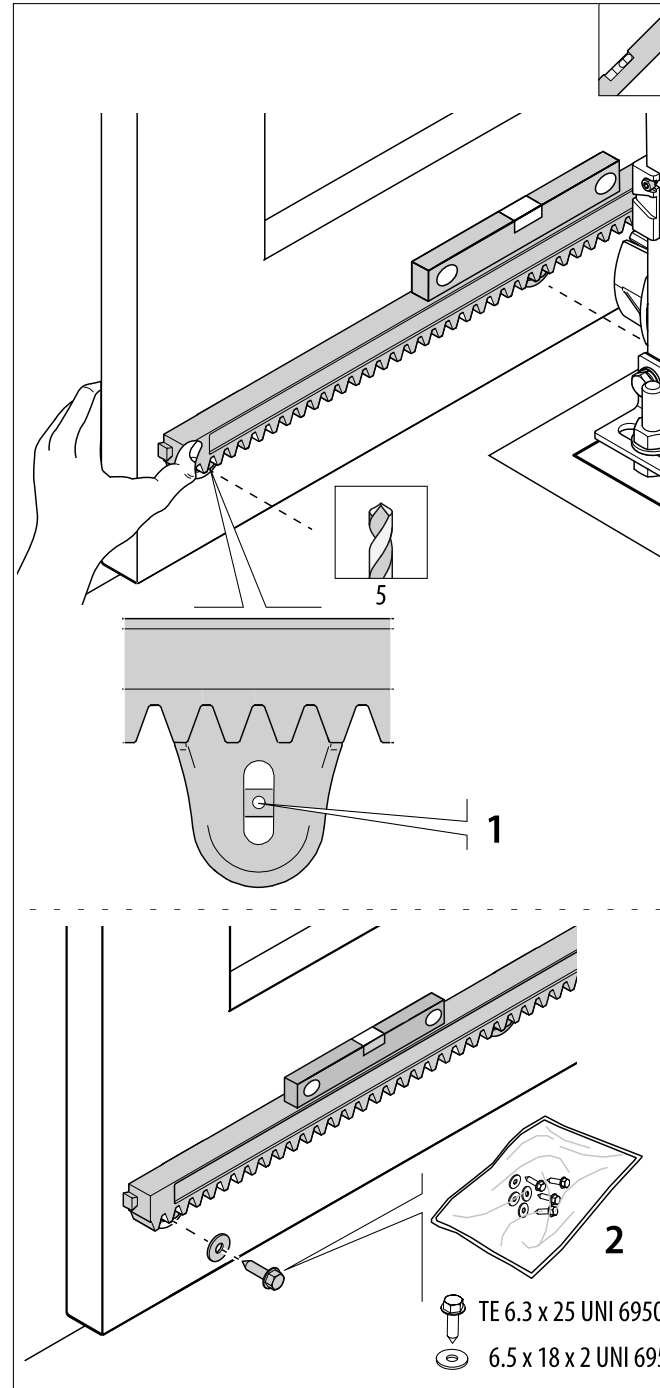

5.5 ADJUSTING AND CHECKING

1. In order for it to work correctly, the rack must never rest on the pinion. Turn all the support nuts clockwise by half a turn (🔧 27) in order to lower the gearmotor. In this way, a constant distance between pinion and rack is obtained for the entire length of travel (🔧 28-A). Make sure that the gearmotor is level by using a spirit level.
2. Check: when the distance between rack and pinion is correct, with the gearmotor stopped, it is possible to rock the leaf manually to the left and right by a few millimetres.
3. Make sure that the rack is centred on the pinion (🔧 28-B).

Move the leaf manually to repeat the checks along the entire length of travel for all the elements of the rack.



Comply with the safety information § Manual operation.

5.6 FASTENING THE GEARMOTOR PERMANENTLY

1. Tighten the upper nuts to the fastening torques indicated in the figure (🔧 29).
2. Press the guards onto the brackets (🔧 30).

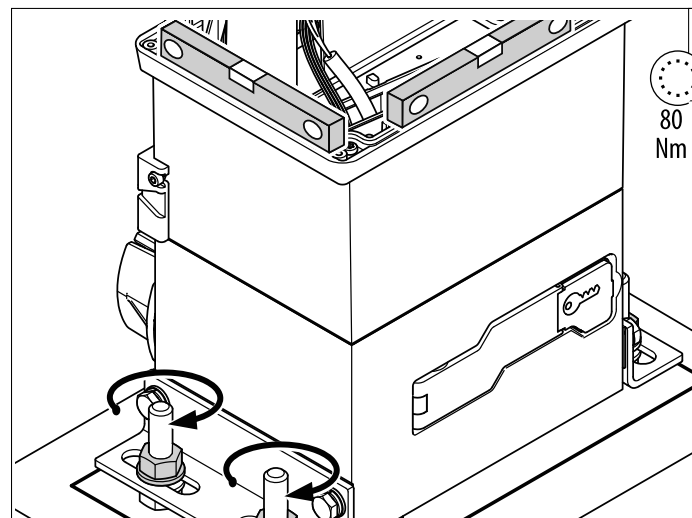
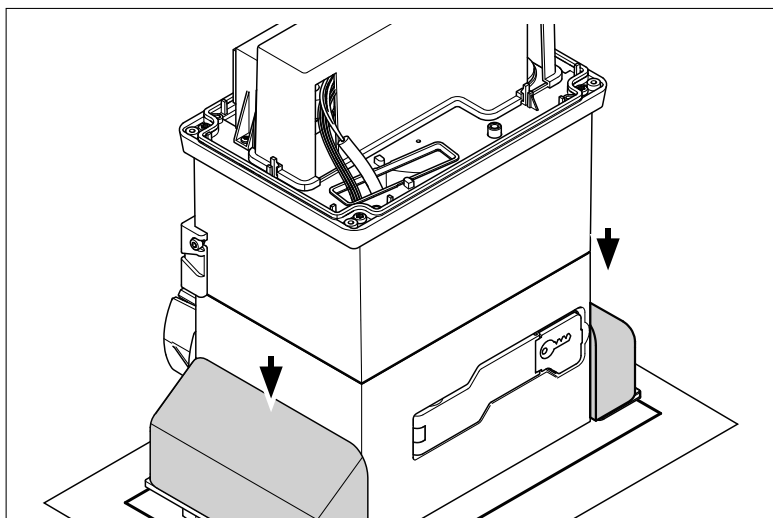
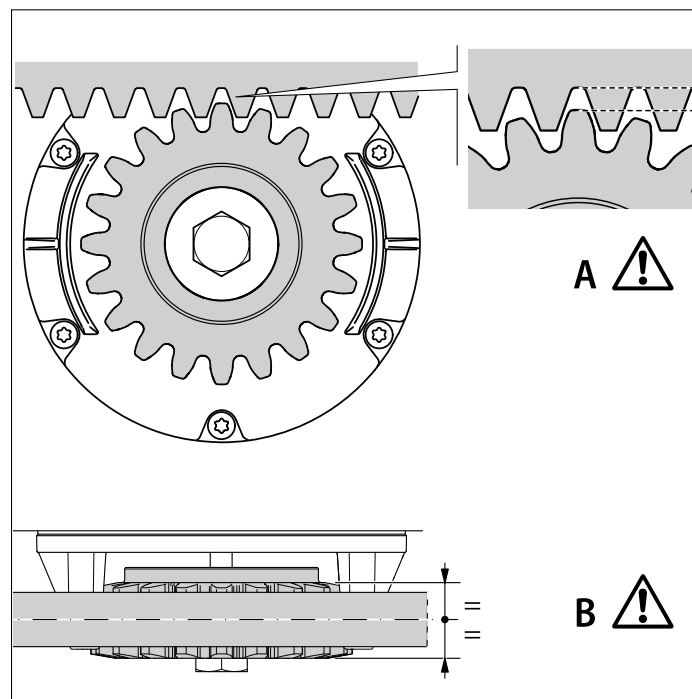
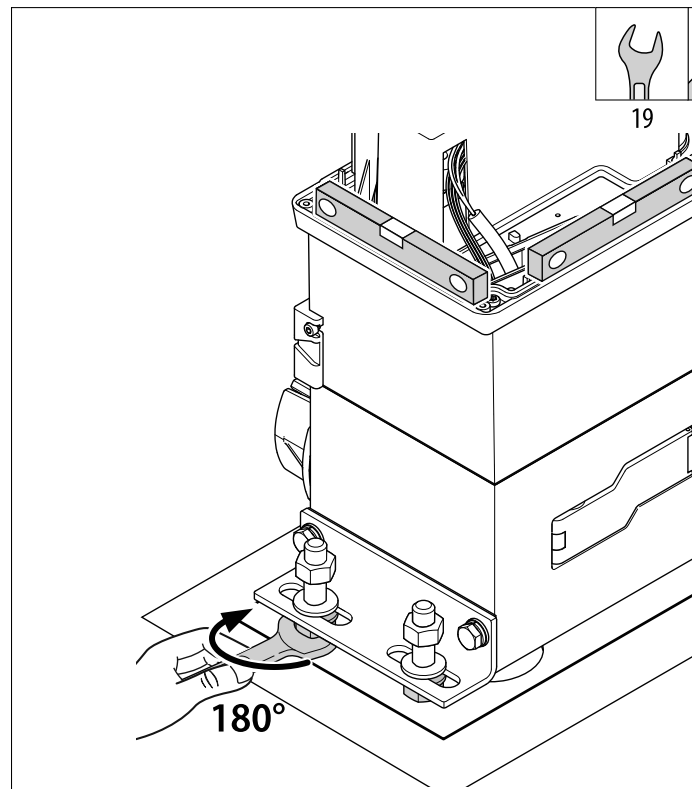

5.7 INSTALLING THE CASING



The casing protects the electronic components and prevents access to moving parts. Never leave the gearmotor unattended without the casing fitted until installation has been completed.



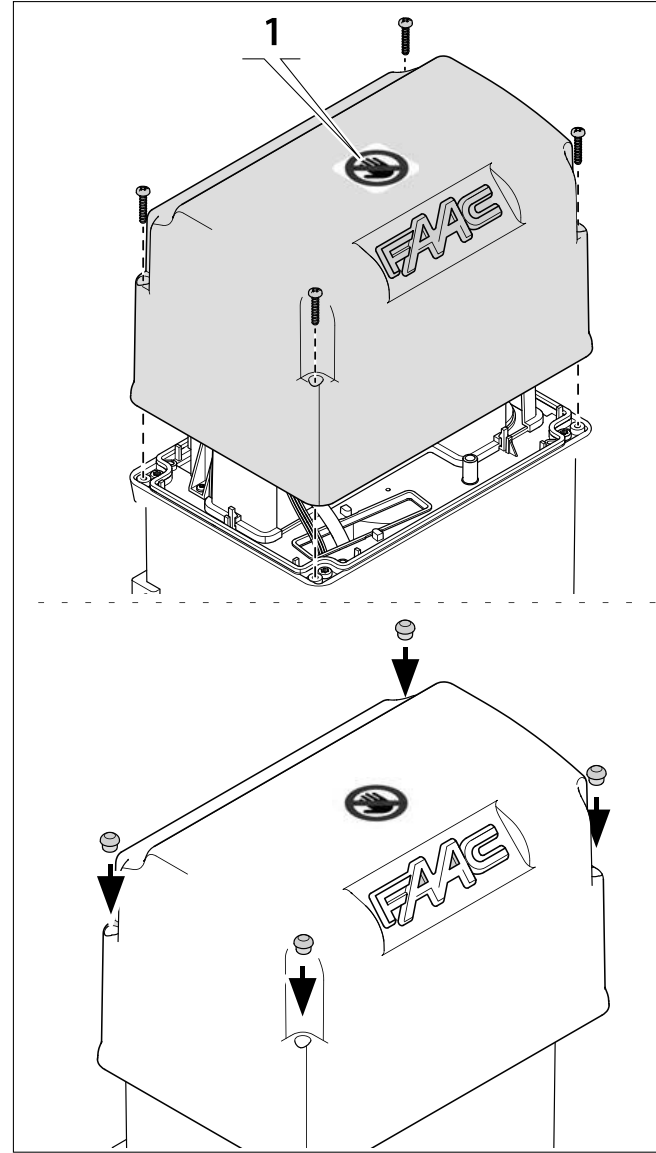

Install the casing once the gearmotor has been set-up.

With reference to  31, apply the adhesive sign 1 to the casing: risk of fingers and hands being trapped due to the rotation of the pinion and the movement of the rack. Install and fasten the casing. Press the screw caps on.



6. OPTIONAL EQUIPMENT

6.1 RELEASE LOCK WITH PERSONALISED KEY

1. Open the release lever using the key. Remove the screw and the locking lever, then remove the nut and the existing lock ( 32).
2. Install the new lock and fasten it using the nut. Insert the locking lever vertically and fasten it using the screw ( 33).
3. Make sure that the release lever works, using the new keys.

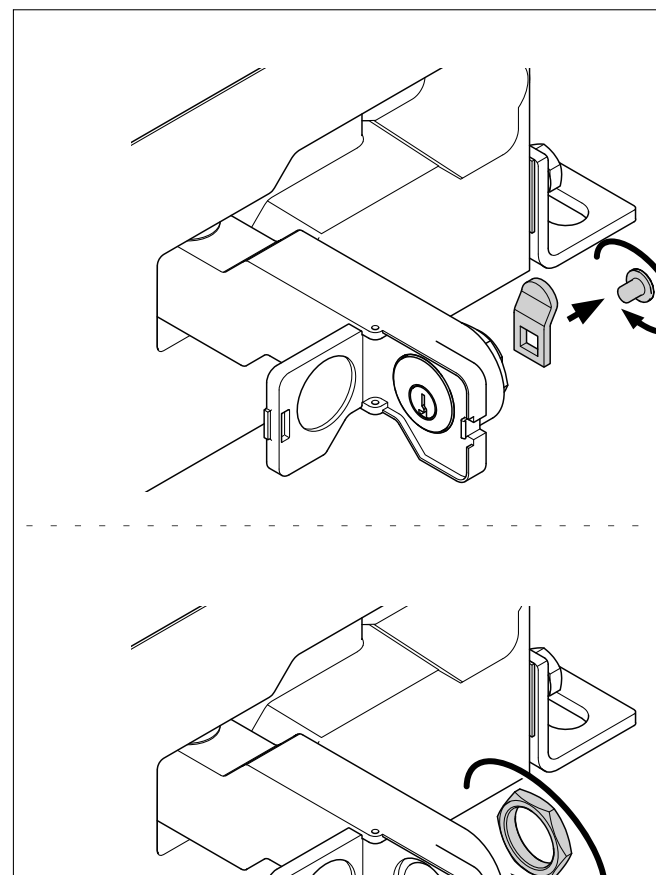
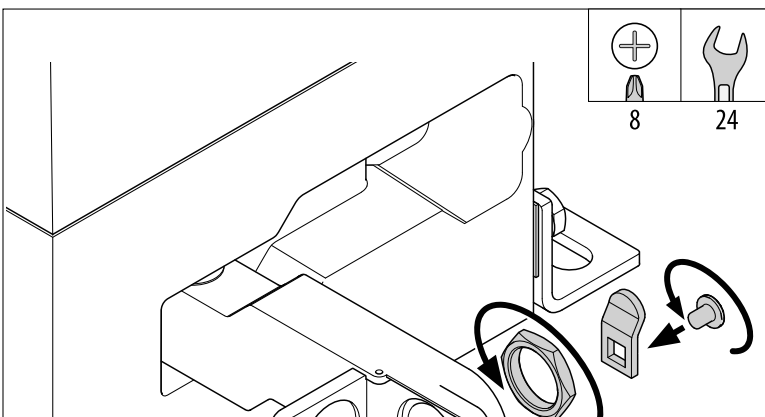

7. ELECTRONIC INSTALLATION

RISKS



PERSONAL PROTECTIVE EQUIPMENT



7.1 REMOVING THE COVER FROM THE BOARD



Only remove the board cover in order to work on electrical connections. Disconnect the power supply to the automation before removing the cover of the electronic board. Only reconnect the power supply after having reinstalled the cover.

The board must be programmed with the board cover installed.

Remove the casing and lift the board cover (🔧35). Temporarily remove the thrust capacitor in order to make this easier.

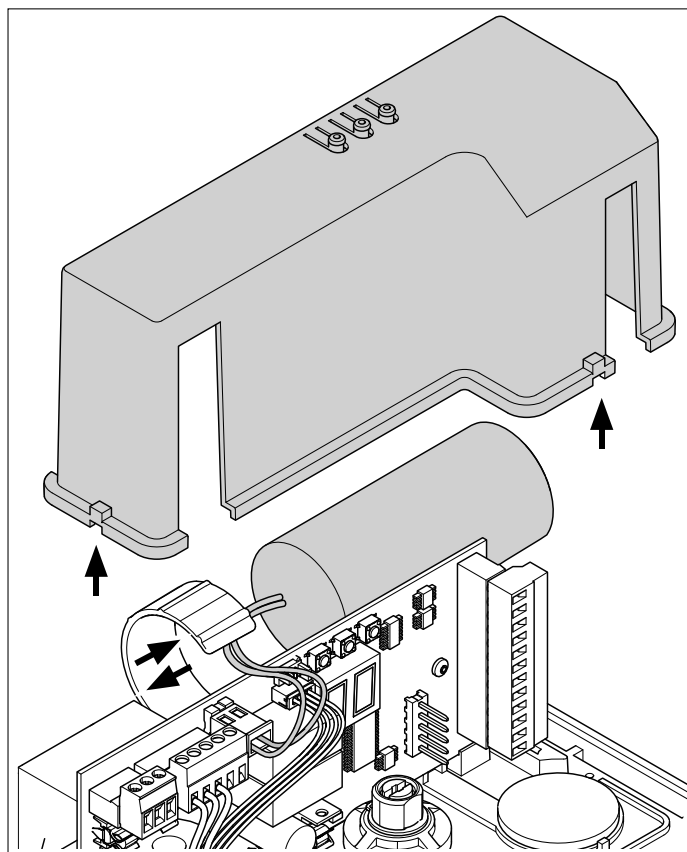

7.2 BOARD 780D

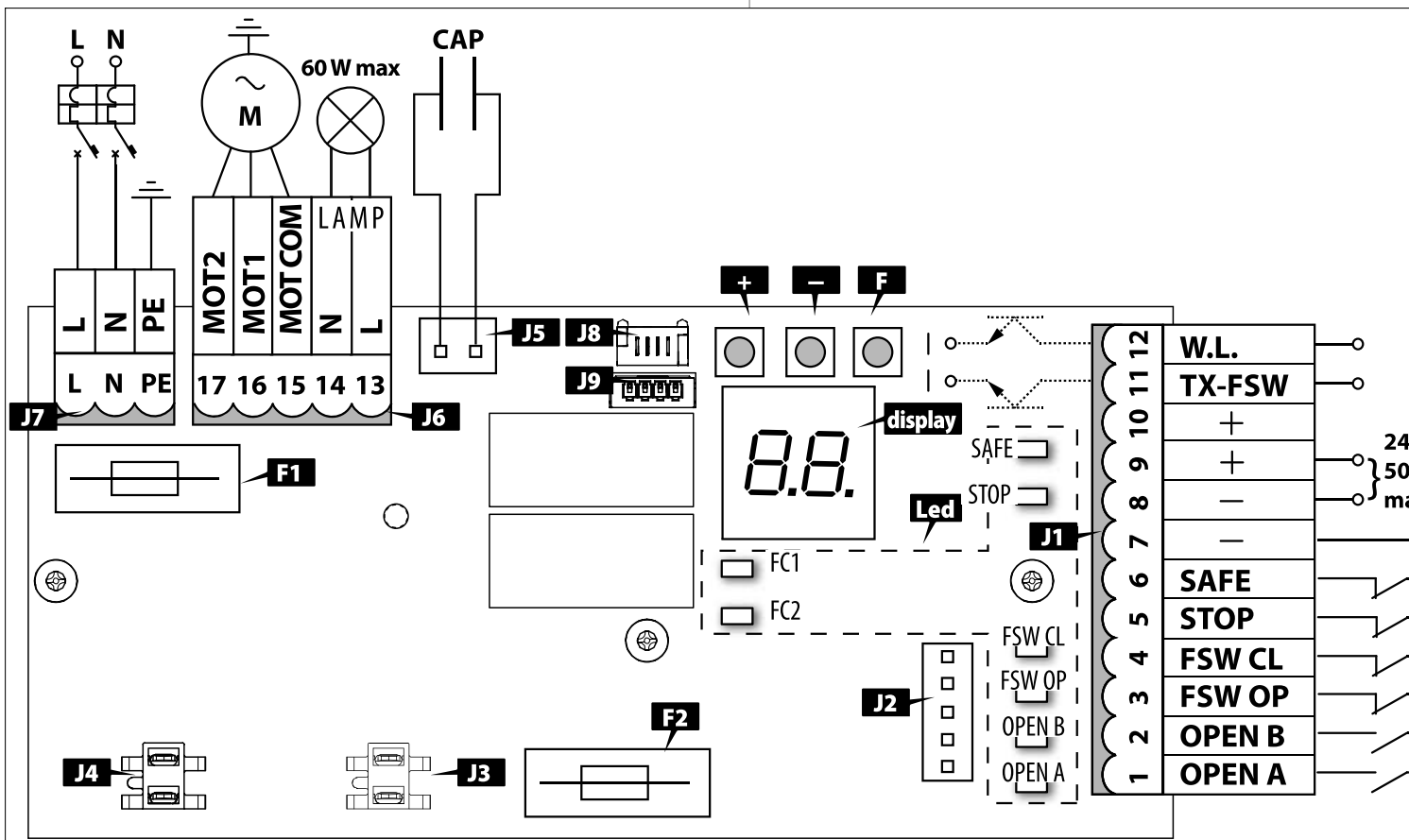

COMPONENTS

J1	Removable terminal board for control devices and accessories (provided in the hardware/accessories)
J2	Connector (5-pin) for radio/decoder boards (as indicated in the FAAC catalogue)
J3-J4	Transformer connectors
J5	Rapid connector for start-up capacitor
J6	Removable terminal board for motor and flashing light
J7	Removable terminal board for mains power supply (provided in the hardware/accessories)

STATUS LEDS

FC1	FC2	Opening/closing limit switch (depending on the opening direction)
SAFE		Sensitive edges
STOP		STOP command
FSW CL		Closing photocells
FSW OP		Opening photocells
OPEN B		Partial opening/closing command
OPEN A		Total opening command
ENCODER		Encoder

	780D [230 V~]	780D [115 V~]
Power supply voltage	220-240 V~ 50/60 Hz	115 V~ 50/60 Hz
Max power	10 W	10 W
Max. motor power	1000 W	1200 W
Max accessories load 24 V $\overline{\text{DC}}$	500 mA	500 mA
Ambient operating temperature	-20°C to +55°C	-20°C to +55°C
Flashing light	230 V~ - 60 W	115 V~ - 60 W

7.3 CONNECTIONS



Carry out the work with the power supply disconnected.



Do not exceed the maximum load of the outputs.

MOTOR

The connection to terminal board J6 is carried out at the factory (☞36).



DO NOT modify the factory connection. If the direction of rotation of the motor has to be reversed, modify function \square I in basic programming.

TERMINAL BOARD J6

15	COM	Common	(grey or blue)
16	MOT 1	Phase	(black)
17	MOT 2	Phase	(brown)

FLASHING LIGHT

Connect the flashing light to terminal board J6 (☞36).

MAGNETIC ENCODER

The magnetic encoder sensor detects the rotation of the magnet on the shaft (☞36).

The sensor is integrated in the board and does not need to be connected.

START-UP CAPACITOR

Connected at the factory: rapid connector J5 (☞37).

TRANSFORMER

The transformer is factory installed (connectors J3-J4) (☞37).

MAGNETIC LIMIT STOP SENSOR

Connected at the factory: rapid connector J9 (☞37).

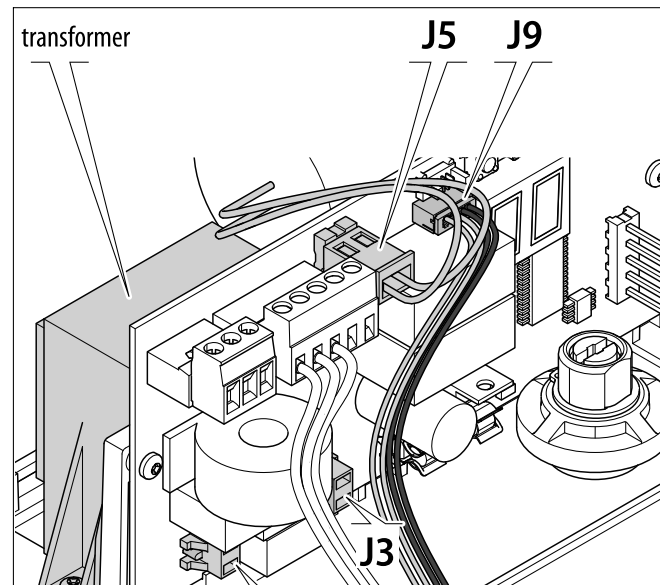
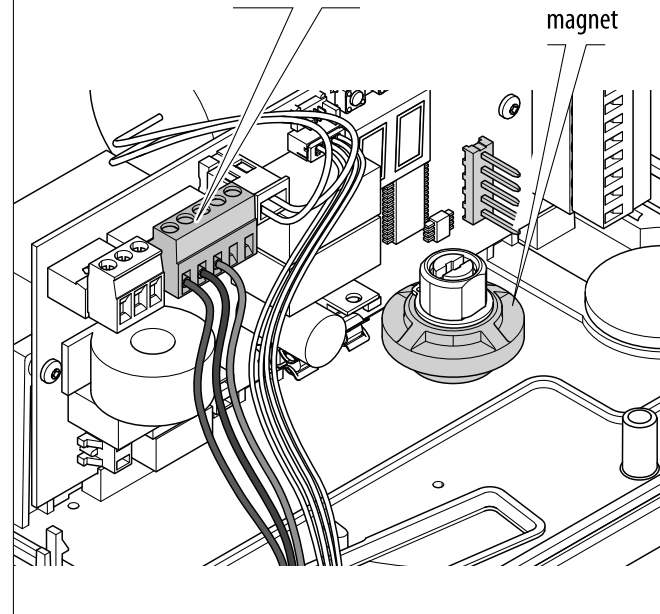
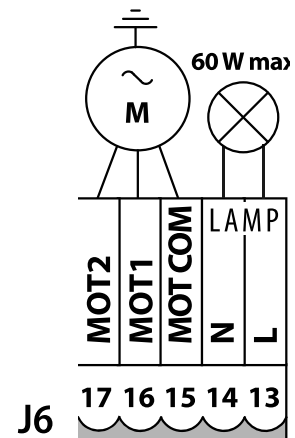

CONTROL DEVICES AND ACCESSORIES

Connect the control devices and the accessories to terminal board J1 (38).

- i** - Multiple contacts on the same NC input must be connected in series.
- Multiple contacts on the same NO input must be connected in parallel.

TERMINAL BOARD J1

1	OPEN A	Connect a push button or another type of NO device. When the contact closes, the leaf opens completely.
2	OPEN B CLOSE	Connect a push button or another type of NO device. When the contact closes, the command is activated according to the programmed operating logic: - in logic A, AP, S, E, or EP: partial opening (OPEN B) - in logic B, C, or B/C: closing (CLOSE)
3	FSW OP	NC contact. Connect the opening photocells (§ Accessories chapter). i Bridge with the negative (TX-FSW) if not used.
4	FSW CL	NC contact. Connect the closing photocells (§ Accessories chapter). i Bridge with the negative (TX-FSW) if not used.
5	STOP	Connect a push button or another type of NC device. i Bridge with the negative (–) if not used.
6	SAFE	When the contact opens, it stops the leaf and locks the gearmotor (which remains locked until the button is reset). NC contact. Connect the sensitive edges. i Bridge with the negative (TX-FSW) if not used.
7, 8	–	Accessories power supply negative and common contacts.
9, 10	+	Accessories power supply positive 24 V (500 mA max.).
11	TX-FSW	Open collector negative for the functional test (failsafe) on inputs 3, 4 and 6. Connect the photocell transmitter/sensitive edges negative to terminal 11 (§ Accessories). i Do not exceed the max load of the output: 24 V $\overline{\text{---}}$, 100 mA.
12	W.L.	Open collector negative configurable for lamp or electric lock (§ Accessories). i Do not exceed the max load of the output: 24 V $\overline{\text{---}}$, 100 mA. If necessary, use a relay and a power supply that is external to the board.

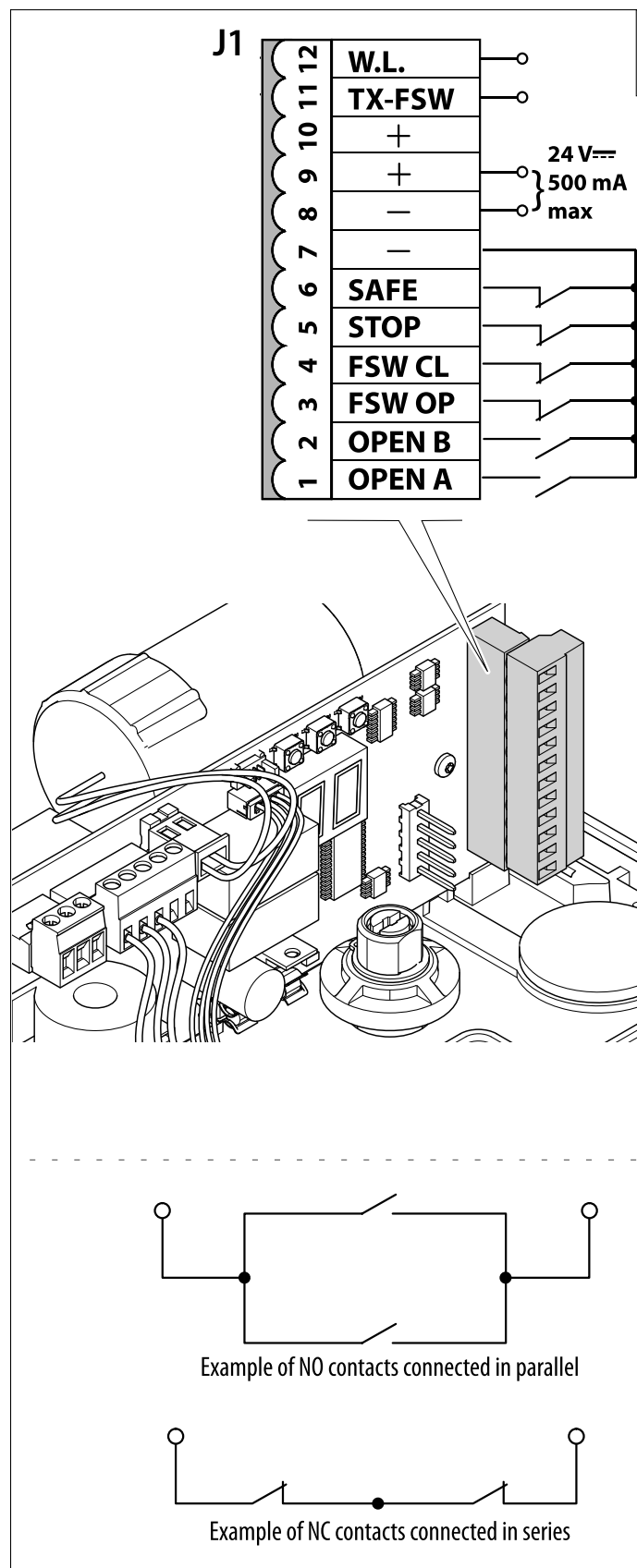

Example of NO contacts connected in parallel

Example of NC contacts connected in series

RADIO RECEIVER/DECODER BOARD



Always disconnect power from the board before installing/removing the receiver/decoder board.



Install a FAAC 5-pin radio receiver board or a decoder board that is compatible, in terms of frequency and coding technology, with the FAAC radio controls that are used:

- a single-channel system only enables the OPEN A radio command
- a two-channel system enables the OPEN A and OPEN B/CLOSE radio commands (according to the programmed operating logic).

Insert the radio receiver or the decoder board into the quick insertion connector J2. The connector is polarised, therefore make sure that it is inserted the correct way round (🔧39).

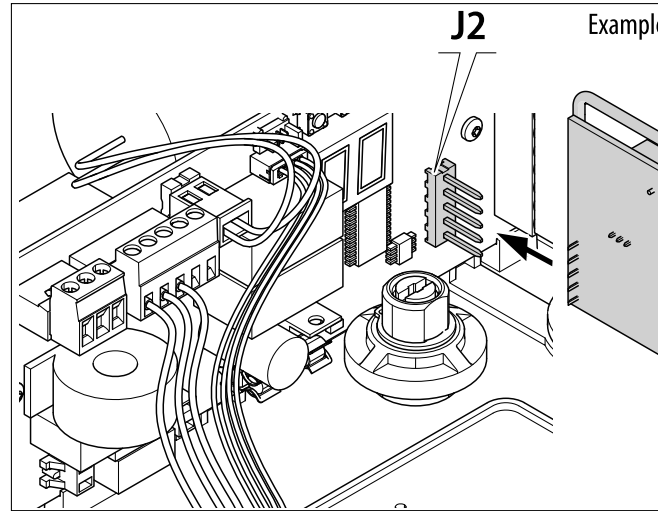

EARTHING THE GEARMOTOR



Cut the power to the system before making the connections.

1. Crimp the earthing conductor of the mains power cable and a similar cable, approximately 20 cm long, onto the cable lug (provided in the hardware/accessories) (🔧40).
2. Fasten the cable lug to the earth connection of the gearmotor using the nuts and washer provided with the hardware/accessories.
3. Connect the free end of the cable to the earth terminal on the board.

POWER CABLE



Cut the power to the system before making the connections.

Connect the phase wire to terminal L and the neutral to terminal N of J7 (🔧40).

Terminal board J7

PE	Earth
N	Neutral
L	Phase

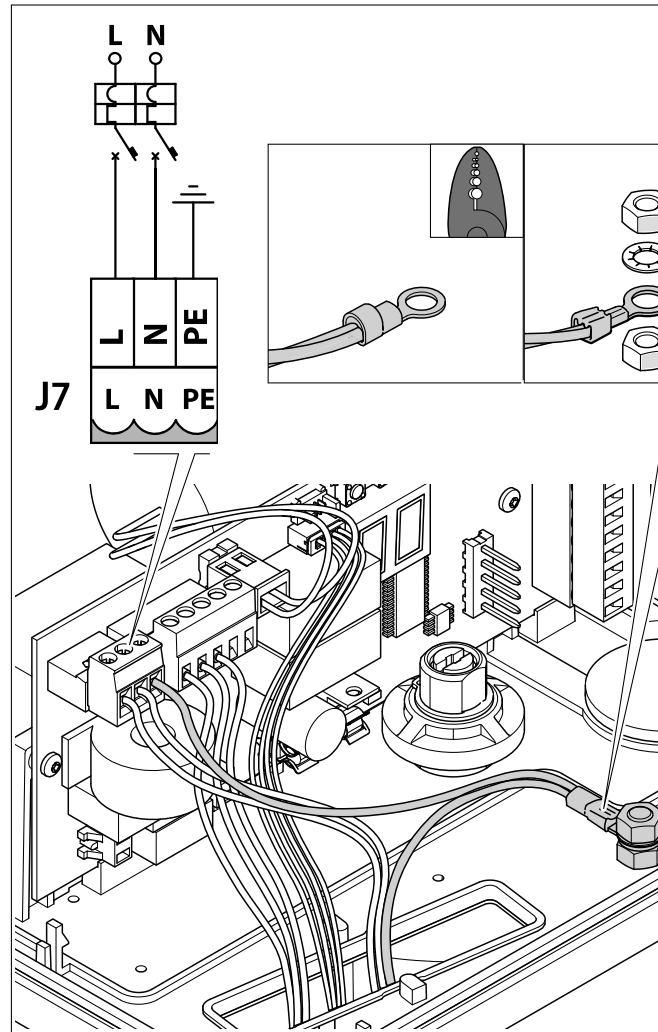

7.4 INSTALLING THE CABLE GLANDS

1. Remove the sheath in order to separate the individual wires.
2. With reference to  41, position elements 1 and 2 (with the slot of each inserted in the pin). Arrange the wires on the rubber strip.
3. Tighten the two elements and fasten them using the screws 3 and the nuts 4.
4. Fasten to the surface using the screws 5.

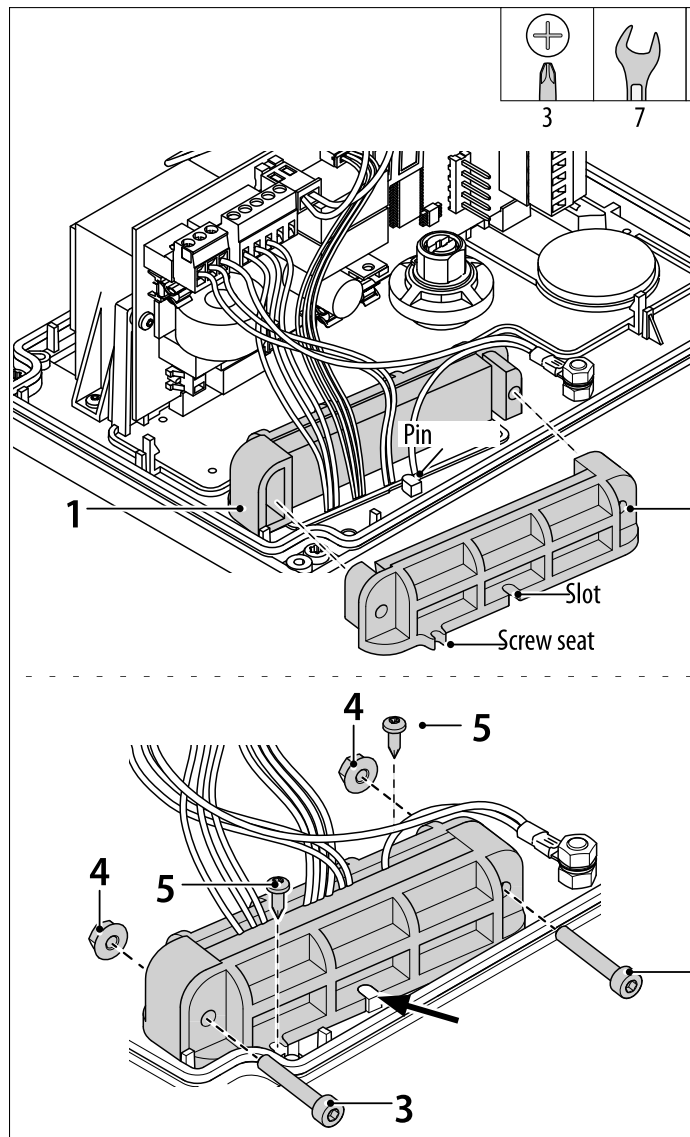

7.5 INSTALLING THE BOARD COVER



The board cover must be installed before switching on the power supply.

1. Install the cover ( 42). Temporarily remove the thrust capacitor in order to make this easier.
2. Make sure that the individual cables pass through the dedicated openings, then push the cover fully onto the 3 retainers (1).

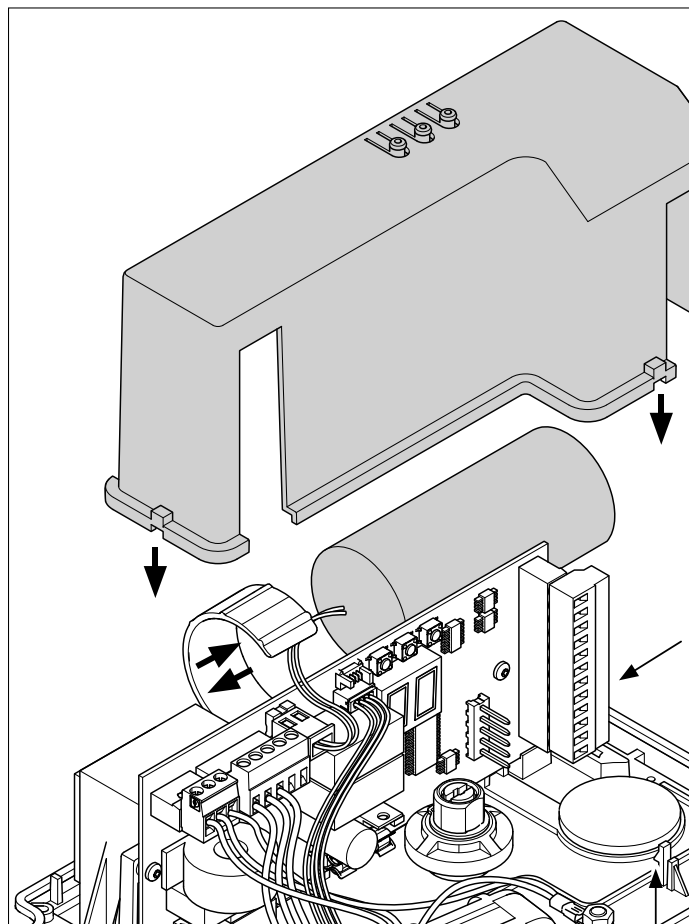

8. START-UP

RISKS



PERSONAL PROTECTIVE EQUIPMENT



Install the board cover before switching on the power supply.

During operation there is a risk of fingers and hands being trapped between the rack, pinion and casing.

Under certain conditions, as a result of prolonged continuous operation, the body of the gearmotor can reach high temperatures. Avoid touching it.

SET-UP PROCEDURE

Carry out the steps, referring to the relative paragraphs and § 10 for the accessories.

1. **With the gearmotor released, move the leaf manually to the halfway position.**
2. **Turn the power supply on and check the status of the LEDs (§ Diagnostics).**
3. **Install the limit switches on the rack.**
4. **Set the opening direction: function $\text{d}|\text{}$ in basic programming.**

The opening direction is established by looking at the 844 E R from the release device side.

5. **Program the pre-limit switch decelerations: function r^{P} in advanced programming.**

The pre-limit switch deceleration reduces the inertia of the gate, allowing the impact forces to fall within the limits indicated in the standard.

The deceleration is carried out only after a complete cycle has taken place from one limit switch to the other.

Each time the power is turned on/restored, the cycles carried out before the complete movement take place at normal or slow speed according to parameter S^{r} in advanced programming.

6. **Adjust the stop positions:**
 - Adjust the position of the limit switches on the rack
 - Set the post-limit switch deceleration and the braking so that the gate stops in the correct positions: functions r^{A} and b^{r} in advanced programming. The leaf must stop a few centimetres before reaching the mechanical stop.

The post-limit switch deceleration is carried out as soon as a limit switch on the gate engages the sensor (the corresponding LED on the board turns off). Braking takes place after the deceleration.

Set the values so that a stop position is obtained in which the sensor is not released by the limit switch. Excessive braking causes the leaf to move backwards after it has stopped.

7. **Set the time-out: function t in advanced programming.**

The time-out prevents the motor from overheating if the limit switch fails to engage: set a time of approximately 10 s longer than the travel time measured between one limit switch and the other.

8. **Adjust the anti-crushing system (§ 8.4).**
9. **Complete the basic / advanced programming, according to the required operating characteristics.**
10. **Memorise the radio controls, if used, following the specific instructions.**
11. **Make sure that the automation is working properly with all the devices installed.**
12. **Install the casing.**

8.1 INSTALLING THE LIMIT SWITCHES



Installing the limit switches involves moving the leaf manually several times. Comply with the safety information § Manual operation.



The two limit switches are marked with different symbols, square / circle.

1. Assemble the limit switches. Insert the spacer (if necessary) as indicated according to the thickness of the rack (☞ 43).
2. Release the gearmotor and open the leaf manually in order to install the opening limit switch.
3. Turn the power on.
4. Position the opening limit switch at the end of the rack as indicated, according to the opening direction of the leaf (☞ 44).
5. Slide the limit switch along the rack in the opening direction until the corresponding LED on the board turns off. Slide the limit switch along the rack for another 4 cm.
6. Fasten using the screws provided (☞ 45).
7. Close the leaf manually and install the closing limit switch.
8. Position the closing limit switch at the end of the rack as indicated, according to the opening direction of the leaf (☞ 44).
9. Slide the limit switch along the rack in the closing direction until the corresponding LED on the board turns off. Slide the limit switch along the rack for another 4 cm.
10. Restore operation.
11. Fasten it permanently after having adjusted the stop positions (§ Set-up procedure) (☞ 45).

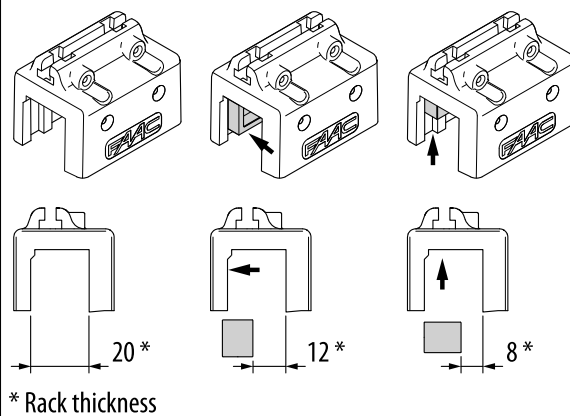
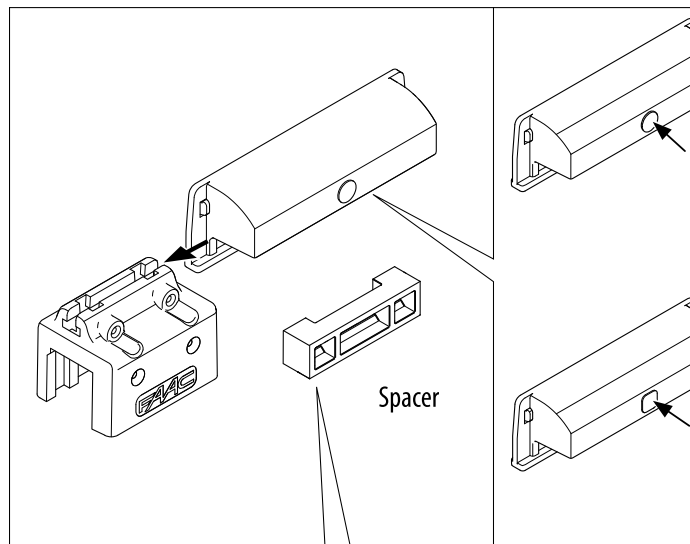

Opening to the right (basic programming: $dI = -\exists$)

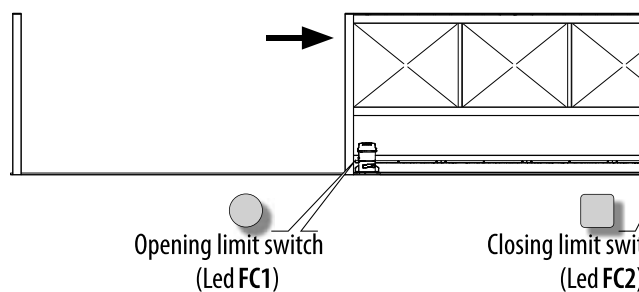

Opening to the left (basic programming: $dI = E-$)

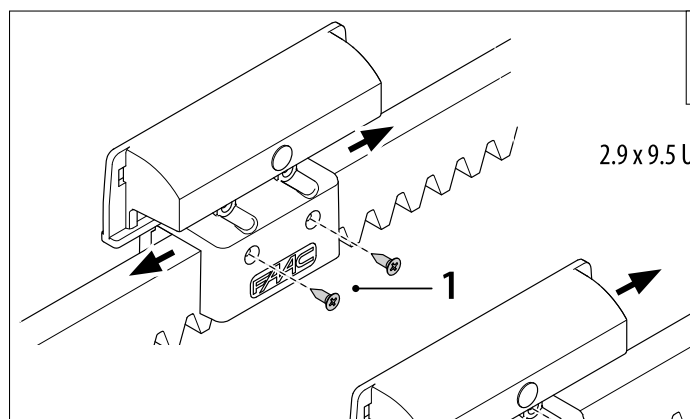
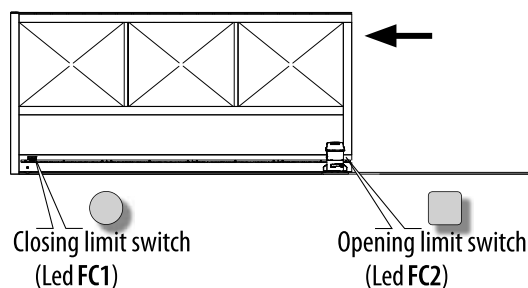

8.2 PROGRAMMING THE BOARD



Programming must be carried out with the board cover installed.

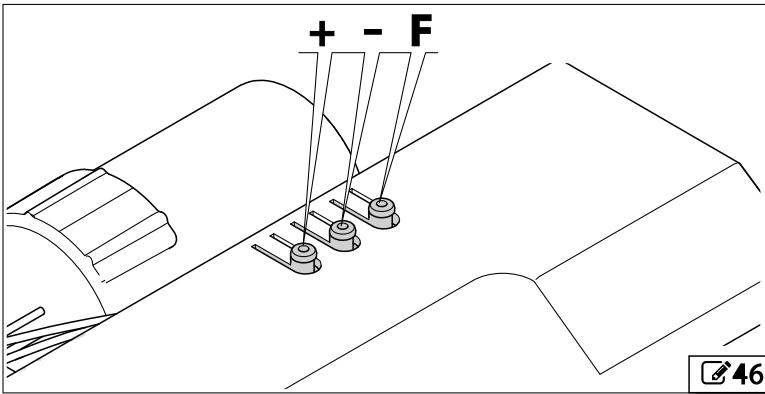

■ Access the basic programming menu

- When the display indicates the status of the automation, press and hold down the **F** button: the display shows the first function: $L \square$. The function is displayed as long as button **F** remains pressed.
- Release button **F**: the display shows the value of the function.

■ Access the advanced programming menu

- When the display indicates the status of the automation, press and hold down the **F** button, then press the **+** button as well: the display shows the first function: $b \square$. The function is displayed as long as the **F** button remains pressed.
- Release the buttons: the display shows the value of the function.

■ Modifying the basic / advanced programming settings

- When the display indicates the value of the function, press the **+** or **-** button to modify it.



Modifications to the values are made and saved immediately.

- Press button **F** to go to the next function. The function is displayed as long as the **F** button remains pressed.
- To exit from the programming mode, scroll through the menu until you reach the $S \square$ function and release the button. The display reverts to the automation status view.

RESTORING FACTORY SETTINGS

This procedure restores all the default values.

1. Make sure that the **SAFE** input is closed (LED on) and that the display indicates the status of the automation.
2. Press and hold down the **+** and **-** buttons simultaneously, then also the **F** button for at least 5 s. When \square and S alternate on the display, release the buttons: the default values have been restored.

8 Basic programming

BASIC FUNCTION

$L \square$ Operating logic:

- | | |
|------------------------------|--|
| R Automatic | $E P$ Semi-automatic step by step |
| $R P$ Automatic step by step | C Dead-man |
| S Automatic Safety | b Semi-automatic B |
| E Semi-automatic | $b C$ Mixed (b opening / C closing) |

$P P$ Pause time (carried out in the automatic logics).

$00 \dots 4.1$ adjustment in steps of 1 s from 0 to 59, then in steps of 10 s

E.g. $41 = 41 \text{ s}$; $4.1 = 4 \text{ min and } 10 \text{ s (max time)}$

$F \square$ Electronic force of gearmotor

$01 \dots 50$ (max)

$d \square$ Opening direction of the leaf, established by looking at the 844 E release device side.

$- \exists$ Opens towards the right

$E -$ Opens towards the left

$S \square$ Exit from programming mode and display the status of the automation

00 Closed

05 Failsafe test failed

01 Opening

06 Closing

02 Stopped

07 Reversing

03 Open

08 Photocells tripped

04 Open in pause

9 Advanced Programming

ADVANCED FUNCTION

$b \square$ Maximum torque at initial thrust

y enabled

$n \square$ not enabled

$S r$ Slow movement every time power is turned on / restored

y enabled

$n \square$ not enabled

$b r$ Final braking

00 not enabled

$01 \dots 20$ adjustment in steps of 0.1 s E.g. $20 = 2 \text{ s (max)}$

$F S$ FailSafe test on inputs FSW CL and FSW OP

y enabled

$n \square$ not enabled

$S A$ FailSafe test on SAFE input

y enabled

$n \square$ not enabled

$P F$ Pre-flashing of 5 s on the LAMP output

$n \square$ not enabled

$\square P$ enabled before opening

$C L$ enabled before closing

$0 C$ enabled before opening and closing

$S P$ Output W.L. configuration

00 LED

$01 \dots 4.1$ courtesy light activation time. Adjustment in steps of 1 s from 0 to 59, then in steps of 10 s. E.g. $41 = 41 \text{ s}$; $4.1 = 4 \text{ min and } 10 \text{ s (max time)}$

When 00 is displayed, press the **-** button to select:

$E l$ closing electric lock

ADVANCED FUNCTION	Default
PH Closing photocells operation (FSW CL) <input checked="" type="checkbox"/> stop, reverse to open when released <input type="checkbox"/> reverse, immediate open	<input type="checkbox"/>
OP Opening photocells operation (FSW OP) <input checked="" type="checkbox"/> reverse, immediate close <input type="checkbox"/> stop with opening when released	<input type="checkbox"/>
EC Encoder obstacle detection sensitivity <input type="checkbox"/> obstacle detection not enabled <input type="checkbox"/> 1 (max sensitivity)... <input type="checkbox"/> 99 (minimum sensitivity)	<input type="checkbox"/> 99
RP Pre-limit switch deceleration <input type="checkbox"/> not enabled <input type="checkbox"/> 1 ... <input type="checkbox"/> 99 duration of slowdown in steps of 0.1 s (if the encoder is not enabled) or in steps of 1 revolution of the motor (the adjustment is more precise if the encoder is enabled)	<input type="checkbox"/> 10
RA Post-limit switch deceleration <input type="checkbox"/> not enabled <input type="checkbox"/> 1 ... <input type="checkbox"/> 20 duration of slowdown in steps of 0.1 s (if the encoder is not enabled) or in steps of 1 revolution of the motor (the adjustment is more precise if the encoder is enabled)	<input type="checkbox"/> 02
PO Partial opening (OPEN B) level <input type="checkbox"/> 1 ... <input type="checkbox"/> 20	<input type="checkbox"/> 05
T Time-out <input type="checkbox"/> 0 ... <input type="checkbox"/> 4.1 adjustment in steps of 1 s from 0 to 59, then in steps of 10 s E.g. <input type="checkbox"/> 41 = 41 s ; <input type="checkbox"/> 4.1 = 4 min and 10 s (max time)	<input type="checkbox"/> 20
AS Request assistance alert <input checked="" type="checkbox"/> enabled <input type="checkbox"/> not enabled	<input type="checkbox"/>
CC Cycle counter <input type="checkbox"/> 0 ... <input type="checkbox"/> 99 (thousands of cycles)	<input type="checkbox"/> 00
SE Exit from programming mode and display the status of the automation: <input type="checkbox"/> 0 Closed <input type="checkbox"/> 1 Opening <input type="checkbox"/> 2 Stopped <input type="checkbox"/> 3 Open <input type="checkbox"/> 4 Open in pause <input type="checkbox"/> 5 Failsafe test failed <input type="checkbox"/> 6 Closing <input type="checkbox"/> 7 Reversing <input type="checkbox"/> 8 Photocells tripped	

8.3 OPERATING LOGICS



The STOP command has priority over all other commands and stops the automation in all the logics. The CLOSE command closes the automation if it is open and stops the automation if it is opening.

■ A AUTOMATIC

This logic only requires the OPEN command to be used.
 OPEN when the automation is closed, causes it to open. The automation closes automatically after the pause time has elapsed.
 OPEN during the pause, resets the pause time.
 OPEN during opening, is ignored.
 OPEN during closing, causes it to reopen.
 If the closing photocells are triggered during the pause time, they reset the pause time.

■ AP AUTOMATIC STEP-BY-STEP

This logic only requires the OPEN command to be used.
 OPEN if the automation is closed, causes it to open. The automation closes automatically after the pause time has elapsed.

If the closing photocells are triggered during the pause time, they reset the pause time.

■ S AUTOMATIC SAFETY

This logic only requires the OPEN command to be used.
 OPEN if the automation is closed, causes it to open. The automation closes automatically after the pause time has elapsed.
 OPEN during the pause, causes it to close.
 OPEN during opening, causes it to close.
 OPEN during closing, causes it to reopen.
 If the closing photocells are triggered during the pause time, they close the automation 5 seconds after they have been released.

■ E SEMI-AUTOMATIC

This logic only requires the OPEN command to be used.
 OPEN if the automation is closed, causes it to open.
 OPEN if the automation is open, causes it to close.
 OPEN during opening, stops it and the following OPEN command closes it.
 OPEN during closing, causes it to reopen.

■ EP SEMI-AUTOMATIC STEP-BY-STEP

This logic only requires the OPEN command to be used.
 OPEN if the automation is closed, causes it to open.
 OPEN if the automation is open, causes it to close.
 OPEN during opening or closing, stops it and the following OPEN command reverses the direction.

■ C DEAD-MAN

This logic requires the maintained OPEN and CLOSE commands to be used.
 CLOSE is obtained by the connection to terminal OPEN B (partial opening is not available). The controls must be activated intentionally and the automation must be visible.
 Maintained OPEN opens the automation.
 Maintained CLOSE closes the automation.
 Movement stops if the photocells are triggered.

■ b SEMI-AUTOMATIC b

This logic requires the OPEN and CLOSE commands to be used.
 CLOSE is obtained by the connection to terminal OPEN B (partial opening is not available).
 OPEN if the automation is closed, causes it to open.
 CLOSE if the automation is open, causes it to close.
 CLOSE during opening, has no effect.
 OPEN during closing, causes it to reopen.
 Movement stops if the photocells are triggered.

■ bC MIXED (b during opening / C during closing)

This logic requires the OPEN impulse command to open and the maintained CLOSE command to close.
 CLOSE is obtained by the connection to terminal OPEN B (partial opening is not available). The CLOSE command must be activated intentionally and the automation must be visible.
 OPEN opens the automation.
 Maintained CLOSE closes the automation.
 Maintained CLOSE during opening has no effect.
 OPEN during closing, causes it to reopen.
 Movement stops if the photocells are triggered.

8.4 ADJUSTING THE ANTI-CRUSHING SYSTEM

The anti-crushing system is realised by a combination of the limitation of static force exerted by the operator in the event of impact and the reverse movement following the detection of the obstacle.

We suggest:

- start by setting the electronic force to the maximum (function F_{\square} in Basic Programming)
- limit the static force to a value lower than 150 N
- set the sensitivity of the obstacle detection system so that obstacles are not detected by mistake
- make sure that the anti-crushing system has been adjusted correctly by using an impact force tester in accordance with standard EN 12453

Refine the adjustments if necessary. Reduce the electronic force, if necessary: function F_{\square} in basic programming.

LIMITING THE STATIC FORCE

The static force is limited by adjusting the mechanical clutch.



The clutch must be adjusted with the power supply disconnected.



The 844 E R is supplied with the clutch adjusted for maximum thrust force.

1. Turn off the power supply and remove the protective cover from the board.
2. Hold the drive shaft in position using a spanner and adjust the screw of the clutch using a screwdriver ($\text{L}47$):
 - $\text{C} (+)$ turn clockwise to increase the force
 - $\text{S} (-)$ turn anti-clockwise to decrease the force
3. Put back the protective cover on the board and turn the power back on.

OBSTACLE DETECTION

The electronic board determines the position of the leaf and the speed of movement via the encoder and detects the presence of an obstacle in the event of impact.

- If an obstacle is detected during opening or closing, the gate reverses for 1 s and then the automation stops.

Adjust the sensitivity of the detection system (if it is too sensitive, it can lead to obstacles to be detected by mistake): function E_{\square} in advanced programming.



Do not disable the obstacle detection system.

CHECKS

Make sure it has been adjusted correctly by using an impact force tester in accordance with standard EN 12453.



If the impact force limits indicated in the standard have been met using the pre-limit switch deceleration, slow movement has to be enabled every time power is turned on / restored: function S_{\square} in advanced programming.

With $S_{\square} = 4$, every time power is turned on / restored, the leaf moves at a slow speed until it has travelled completely between one limit switch and the other.

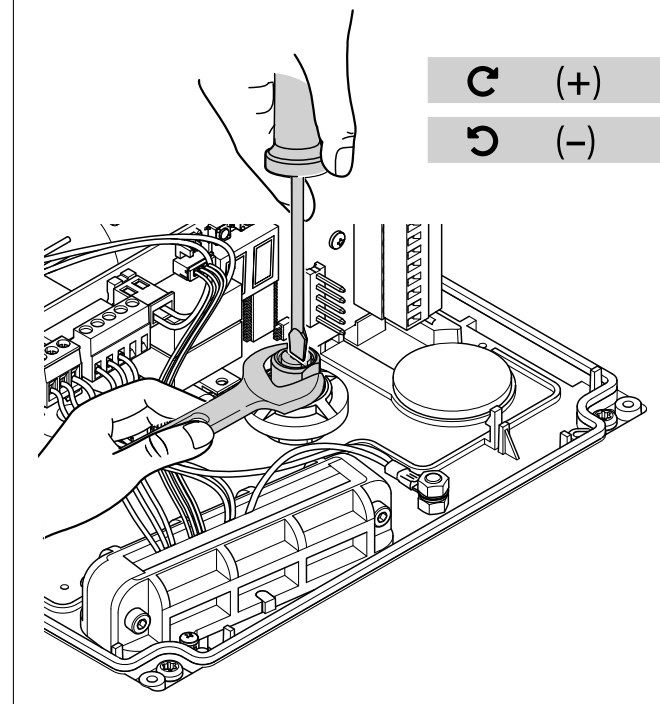
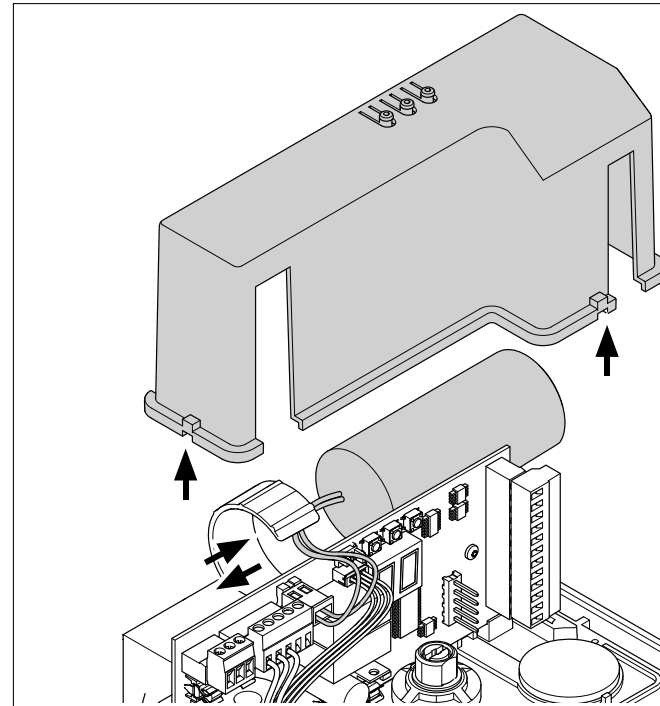

For non-EU countries, if there are no specific local regulations, the static force must be less than 150 N.

9. PUTTING INTO SERVICE

9.1 FINAL OPERATIONS

RISKS



PERSONAL PROTECTIVE EQUIPMENT



1. Make sure that the forces generated by the leaf are within the limits permitted by the current regulations. Use an impact force tester in accordance with standard EN 12453. For non-EU countries, if there are no specific local regulations, the static force must be less than 150 N. If necessary, adjust the anti-crushing system and the sensitivity of the obstacle detection system.
2. Make sure that the maximum force required to move the leaf manually is less than 225 N in residential areas and 260 N in industrial or commercial areas.
3. Highlight all areas with adequate warning signs in which there are still residual risks, even if all possible safety measures having been adopted.
4. Place a "DANGER, AUTOMATIC MOVEMENT" sign (not supplied) in a prominent position on the gate.
5. Attach the CE marking to the gate.
6. Fill out the EC declaration of conformity and the system register.
7. Give the EC Declaration, the system register with the maintenance plan and the instructions for use of the automation to the system owner/operator.

10. ACCESSORIES

RISKS



PERSONAL PROTECTIVE EQUIPMENT



- Disconnect the power supply to the system before removing the cover of the board. Only remove the board cover in order to work on electrical connections. Only reconnect the power supply after having reinstalled the cover.

10.1 FLASHING LIGHT

The flashing light indicates that the automation is moving. If pre-flashing is enabled, it starts 5 s before movement begins.

- Use a 230 V~ flashing light with a max load of 60 W.

1. Install the flashing light in a position that is easily visible from inside and outside the property.
2. Connect to the LAMP terminals on J6 .
3. Program the pre-flashing. Function PF in Advanced programming:

PF = □□ no pre-flashing
 PF = □P pre-flashing only before opening

TERMINAL BOARD J6

13	LAMP L	Phase
14	LAMP N	Neutral

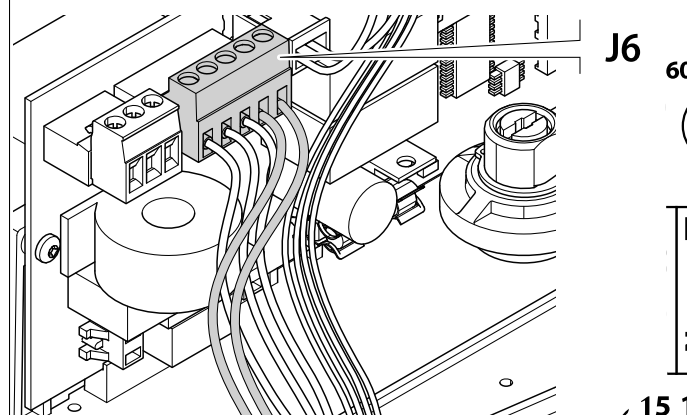

J6

60

15

10.2 PHOTOCELLS

! Photocells are additional devices that reduce the likelihood of contact with the moving leaf, but they are not safety devices according to standard EN 12978.

i Use photocells with a NC relay contact. If multiple photocells are used, the contacts must be connected in series. If the photocell inputs are not used, they must be bridged to terminal TX-FSW:

- no opening photocell, bridge terminals FSW OP and TX-FSW
- no closing photocell, bridge terminals FSW CL and TX-FSW

1. Position and connect the photocells according to their use (49).
2. Program the way the automation should operate when the photocells are triggered:
functions Ph, oP in advanced programming.
3. Enable the FailSafe test (optional):
FS = 4 in advanced programming

Opening photocells-FSW OP. They must be positioned to monitor the opening stroke. They must be connected as indicated in 50A (one pair) or B (two pairs in series). They are only active during opening.

Operation: function oP in advanced programming.

- oP = 4 reverse, immediate close
- oP = no stop with opening when released

Closing photocells-FSW CL. They must be positioned to monitor the access when it is closing. They must be connected as indicated in 50A (one pair) or B (two pairs in series). They are only active during closing.

Operation: function Ph in advanced programming.

- Ph = 4 stop, reverse to open when released
- Ph = no reverse, immediate open

FailSafe test

The functional test is carried out before each movement. It consists of momentarily interrupting the power supply to the devices and checking the change in status of the input.

If the test fails, the board prevents the automation from moving (status 5).

To enable the test:

- connect the transmitter negative to terminal TX-FSW
- enable the FailSafe test in advanced programming: FS = 4

i The maximum power consumption at terminal 11 is 100 mA.

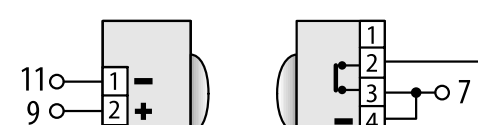
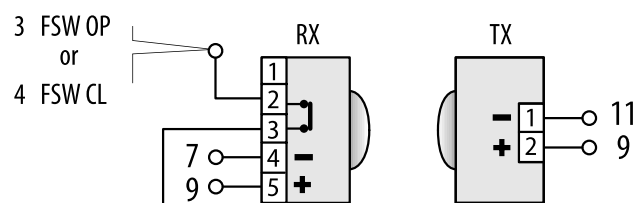
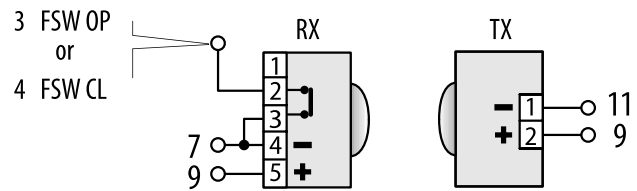
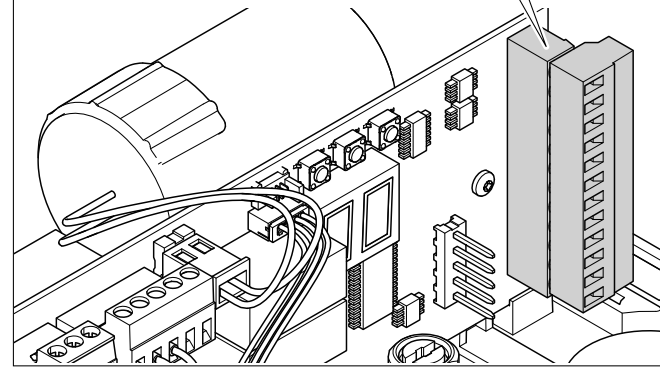
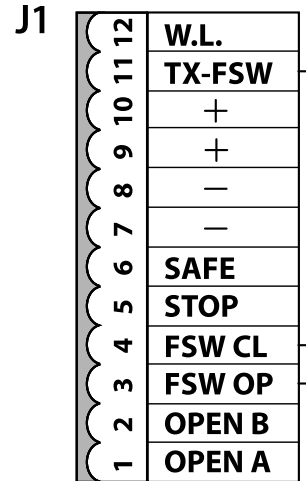
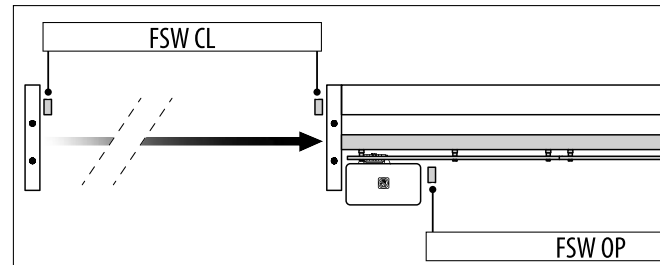

10.3 SENSITIVE EDGES

i Use sensitive edges with a NC relay contact. If multiple sensitive edges are used, the contacts must be connected in series. If the SAFE input is not used, it must be bridged to terminal TX-FSW.

1. Install and connect the sensitive edges 51. If the CN 60 E is used, a DIN rail can be installed for attaching the control unit 52.
2. Enable the FailSafe test (optional):
 $SA = 3$ in advanced programming

Operation: if the sensitive edges are triggered, it causes the direction of travel to be reversed for 1 s, and then the automation stops.

■ FailSafe test

The functional test is carried out before each movement. It consists of momentarily interrupting the power supply to the sensitive edges and checking the change in status of the input.

If the test fails, the board prevents the automation from moving (status 05).

To enable the test:

- connect the device negative to terminal TX-FSW
- enable the FailSafe test in advanced programming: $SA = 3$

i The maximum power consumption at terminal 11 is 100 mA.

10.4 LED/TIMED LAMP, TRAFFIC LIGHT CONTROL, ELECTRIC LOCK

i Do not exceed the maximum load of output W.L. (24 V $\overline{\text{---}}$, 100 mA). If necessary, use a relay and a power supply that is external to the board.

The output can be programmed for various functions.

1. Connect the device 53.
2. Program the output: function SP in advanced programming.

LED. Program $SP = 00$ to activate the remote signalling of the automation status:

automation	LED
closed	off
opening	on
open	on
closing	flashing

■ Courtesy light. Set the switch-on time:

The time can be adjusted from 01 to 59 s, in 1 second steps. Then, from 1.0 to 4.1 minutes in 10 second steps.

$SP = 01 \dots 4.1$ (4 min and 10 s - maximum time)

■ Electric lock. Program the activation of the electric lock:

$SP = E1$ before opening

$SP = E2$ before opening and closing

■ Traffic light control. Program the operation:

$SP = E3$ traffic light control on when the automation is open and open in pause, it turns off 3 s before the start of closing (during which there is pre-flashing on the LAMP output).

$SP = E4$ traffic light control on only when the automation is closed

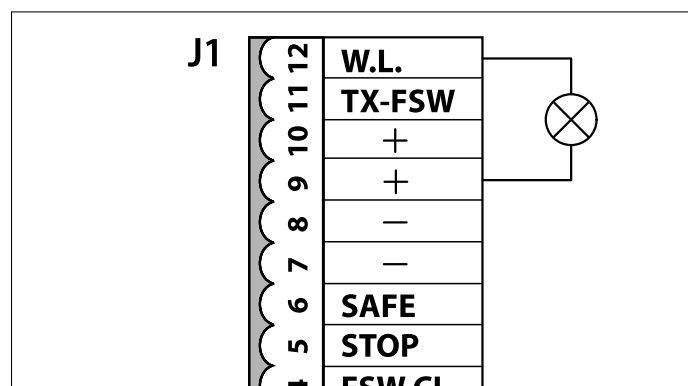
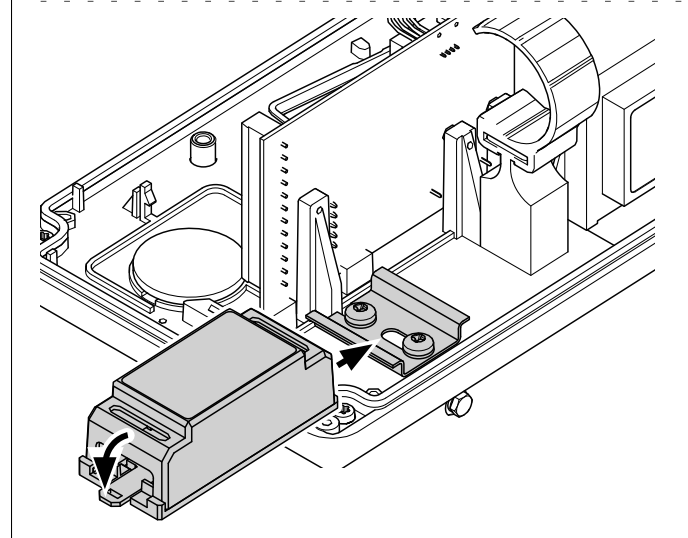
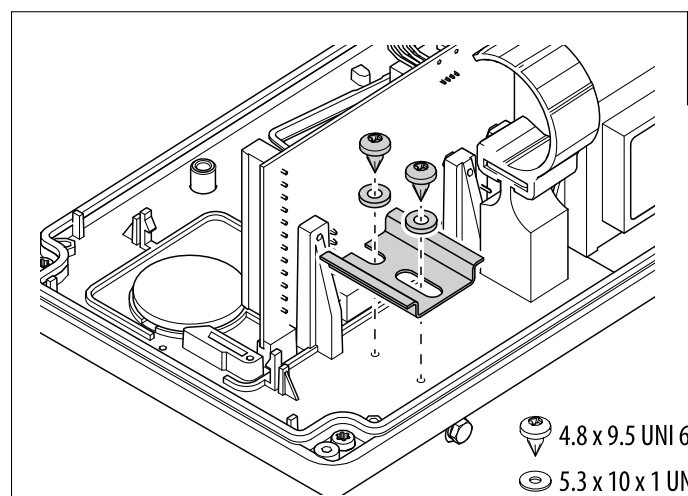
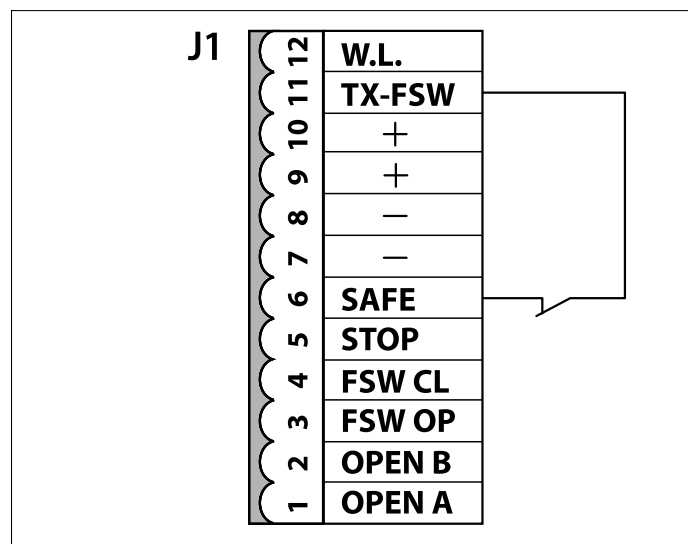

11. DIAGNOSTICS

11.1 CONNECTION STATUS

Move the gate to its halfway position, turn the power on and check the LEDs on the board (10): the status of the LEDs must correspond to those indicated in bold. Otherwise, check the connections.

11.2 STATUS OF THE AUTOMATION

When the board is not being programmed, 2 digits, which indicate the status of the automation, are shown on the display (11).

11.3 REQUEST ASSISTANCE ALERT

If enabled in advanced programming, the alert is activated when the scheduled maintenance counter reaches zero.

The alert consists of the flashing light pre-flashing for 2 s before each movement.

1. Enable the alert in advanced programming: function $AS=4$
2. Set the cycle counter in advanced programming: function RC .
 - The counter corresponds to thousands of cycles and decreases every time 1000 work cycles have been carried out, the remaining cycles are indicated in thousands.

10 LEDs on the board

i bold indicates the condition of the LEDs with the board powered at its halfway position and no connected device active.

LED		●	○
FC1	Limit switch 1	not engaged	en
FC2	Limit switch 2	not engaged	en
OPEN B	Partial opening command	active	no
OPEN A	Total opening command	active	no
FSW OP	Opening photocells	not engaged	en
FSW CL	Closing photocells	not engaged	en
STOP	Stop	not active	act
SAFE	Sensitive edges	not active	act
ENCODER	* Flashes when moving		

○ off (contact open) ● on (contact closed) * flashing

11 Status of the automation

Display	
00	Closed
01	Opening
02	Stopped
03	Open
04	Open in pause
05	Failsafe test failed
06	Closing
07	Reversing
08	Photocells triggered

12. MAINTENANCE

RISKS



PERSONAL PROTECTIVE EQUIPMENT



⚡ Before performing any maintenance, disconnect the mains power supply. If the disconnecting switch is not visible, apply a "ATTENTION - Maintenance in progress" sign. Restore the power supply once maintenance is complete and after tidying up the area.

! Maintenance must be performed by the installer/maintenance technician. Comply with all the safety instructions and recommendations provided in this manual. Close off the work site and prevent access/transit. Do not leave the work site unattended.

The work area must be kept tidy and clear upon completing maintenance. Before starting activities, wait for the components subject to heating to cool down.

Do not modify the original components in any way. FAAC S.p.A. disclaims any liability for damage caused by components that are modified or tampered with.

12.1 ROUTINE MAINTENANCE

The table **12** lists the operations that must be performed on a regular basis in order to keep the automation working reliably and safely; these are given purely as a guideline and should not be considered exhaustive. The installer/machine manufacturer is responsible for drawing up the maintenance plan for the automation, supplementing this list or modifying the maintenance intervals according to the machine characteristics.

12 Scheduled maintenance

Operations	Frequency
Structures	
Check the plinth, the structures and components of the building/fence adjacent to the automation, ensuring there is no damage, cracking or subsidence.	12
Check the gate's area of movement, ensuring it is free from obstacles, objects or deposits which would reduce the effectiveness of the safety measures.	12
Check that there are no gaps in the perimeter fence and that any protective grilles in the area where it overlaps with the mobile leaf are intact.	12
Ensure that there are no sharp protrusions which could represent a perforation or hooking hazard.	12
Gate	
Check the gate, ensuring it is intact and free of deformations, rust etc.	12
Check that there are no slots/openings on the leaf and that any protective grilles are intact.	12
Check that screws and bolts are correctly tightened.	12
Check that the sliding guides are straight and not excessively worn.	12
Check that the bearings are in good condition and there is no friction.	12
Check that the mechanical stops are fastened solidly and in good condition. This check must be performed on both sides, simulating any knocks which could occur during use.	12
Check the wheels, ensuring that they are intact, correctly fastened and free of deformation, wear and rust.	12
Check the rack, ensure it is straight, not worn, that it is the correct distance from the pinion along its entire length and correctly fastened to the gate.	12
Cantilever gates, check the solidity of the guide system for the suspended leaf and the counterweight, where present.	12
Check the containing guide and the anti-tipping column, ensuring they are correctly fastened and intact.	12
Perform a general clean of the area of movement of the gate.	12
Gearmotor	
Check that the gearmotor is intact and correctly fastened.	12
Check that the pinion is correctly keyed to the shaft and tightened correctly.	12
Check that the hand guard around the pinion is present and intact.	12
Check that it is irreversible.	12
Check that there are no oil leaks.	12
Check the condition of the cables, cable glands and junction boxes.	12
Electronic equipment	
Check the condition of the power cables and connections, cable glands and junction boxes.	12
Check that the connectors and wiring are intact.	12
Check that there are no signs of overheating, burning etc. of electronic components.	12
Check that the earth connections are intact.	12
Check the operation of the circuit breaker and differential switch.	12
Check that the limit switch is intact and that it operates correctly.	12
Control devices	
Check that the installed devices and radio controls are in good condition and that they operate correctly.	12
Sensitive edaes	

Photocells

Check condition, fastening and correct operation.

Check the columns, making sure that they are intact, correctly fastened and they are not deformed etc.

Flashing light

Check condition, fastening and correct operation.

Electric locks

Check condition, fastening and correct operation.

Clean the seats.

Access control

Check that the gate opens only when an authorised user is recognised.

Complete automation system

Check that the automation operates correctly, following the set logic, when using the various control devices.

Check that the gate moves correctly - smooth, regular and without abnormal noise.

Check that both the opening and closing speed are correct and that the positions and slow-downs provided for are respected.

Check that the manual release operates correctly: when the release mechanism is activated, it must only be possible to move the gate manually and not electrically.

Check that the caps on the locks are present.

Check that the maximum force required to move the leaf manually is less than 225 N in residential areas and 260 N in industrial or commercial areas.

Check that the sensitive edges operate correctly when an obstacle is detected.

Check that the encoder operates correctly when an obstacle is detected.

Check that each pair of photocells is working correctly.

Check that there is no optical/light interference between the pairs of photocells.

Check the force limitation curve (standard EN 12453).

Check that all necessary signage and warnings are present, intact and legible, including residual risks, exclusive use etc.

Check that the gate's CE marking and the DANGER, AUTOMATIC MOVEMENT warning sign is present, intact and legible.

13. INSTRUCTIONS FOR USE

It is the responsibility of the machine installer/manufacturer to draft the user instructions of the automation in accordance with the Machinery Directive, including all the required information and instructions based on the characteristics of the automation.

The guidelines below, which are purely indicative and in no way exhaustive, help the installer draft the user instructions.

 The installer must provide the owner/operator of the automation with the EC Declaration, the system Logbook with the maintenance schedule and the user instructions of the automation.

The installer must inform the owner/operator of any residual risks and the intended use and ways in which the machine should not be used.

The owner is responsible for operating the automation and must:

- comply with all User instructions provided by the installer/maintenance technician and the Safety recommendations
- keep the user instructions
- have the maintenance schedule implemented
- keep the system Logbook, which must be completed by the maintenance technician at the end of all servicing

13.1 SAFETY RECOMMENDATIONS

Systems that use FAAC series 844 E R gearmotors are designed for use with vehicular and/or pedestrian traffic.

The user must be in good physical and mental health and be aware of and responsible for the dangers which use of the product can lead to.

-  - Do not remain in or walk/drive through the area of operation of the automation while it is moving.
- Do not use the automation when the area of operation is not free of persons, animals or objects.
 - Do not allow children to approach or play in the area of operation of the automation.
 - Do not try to prevent the movement of the automation.
 - Do not climb on, hold onto or let yourself be pulled by the leaf. Do not climb onto or sit on the gearmotor.
 - Do not allow the devices to be used by anyone who is not specifically authorised and trained to do so.
 - Do not allow the devices to be controlled by children or persons with mental and physical deficiencies unless they are supervised by an adult who is responsible for their safety.
 - Do not use the automation with the fixed and/or mobile guards removed or altered.
 - Do not use the automation in the presence of faults which could compromise safety.
 - Do not expose the automation to corrosive chemicals or atmospheric agents. Do not allow water jets of any type or size to come into direct contact with the gearmotor.
 - Do not expose the automation to flammable gases or fumes.
 - Do not perform any work on the components of the automation.

 During operation, there is a risk of fingers and hands being trapped between the rack, pinion and casing.

 Under certain conditions, as a result of prolonged continuous operation, the body of the gearmotor can reach high temperatures. Avoid touching it

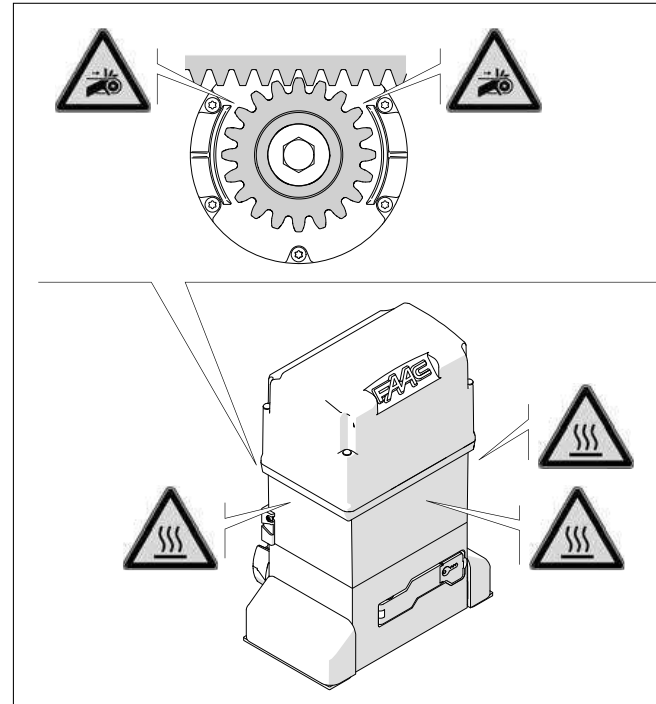

13.2 EMERGENCY USE

Environmental phenomena, even occasional, such as ice, snow and strong wind may hinder correct operation of the automation and affect component integrity and may become a potential source of danger.

In emergencies or if there is a fault, turn off the power supply to the automation. If the leaf can be moved safely by hand, use the MANUAL OPERATION mode; otherwise place the automation out of service until it has been reset/repaired.

In the case of a breakdown, the automation must be reset/repaired exclusively by the installer/maintenance technician.

Releasing the gearmotor

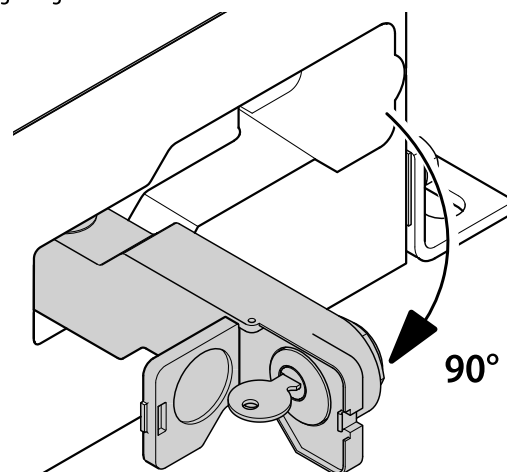

Restoring operation

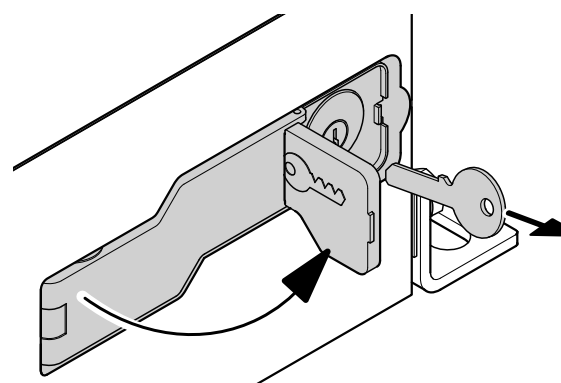

13.3 MANUAL OPERATION

In order to operate the leaf manually, the gearmotor has to be released using the key provided.



Disconnect the power supply from the automation before releasing the gearmotor.

During manual operation, gently guide the leaf the whole way. Do not push it and let it slide freely.

Do not leave the gearmotor in the released mode: restore automatic operation after moving it manually.

RELEASING THE GEARMOTOR

1. Open the lock cover.
2. Insert the key and turn it clockwise by 90°.
3. Open the release lever by 90° (🔧56).

RESTORING OPERATION

1. Close the release lever. Turn the key so that it is vertical and remove it (🔧56).
2. Close the lock cover.
3. Move the leaf manually to make sure that the mechanical system meshes correctly.



Make sure that the gate is at its opening or closing end of travel position (the relative limit switch must be engaged) before turning the power back on and operating the automation.

PLAN VIEW

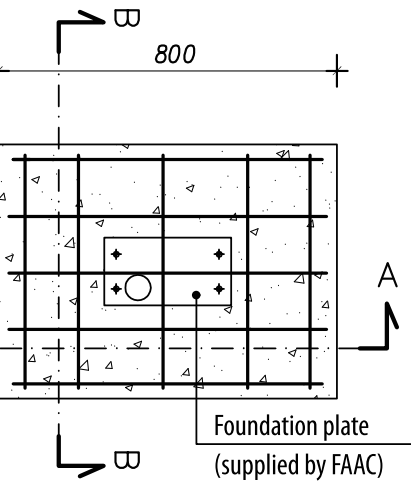

REINFORCEMENTS

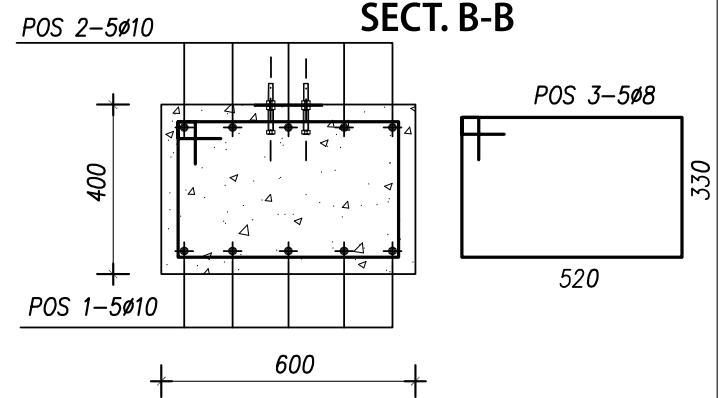
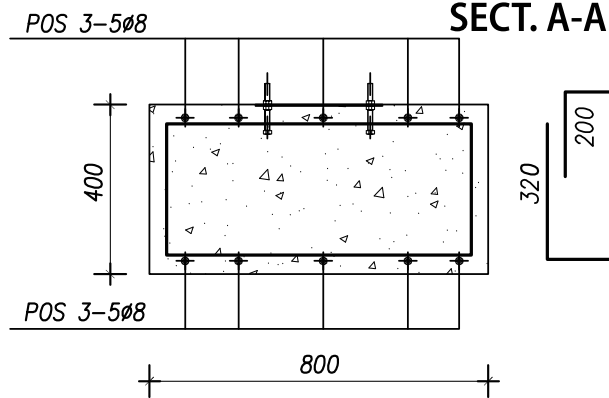

FOUNDATION PLATE ANCHORING

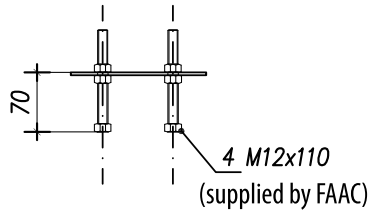
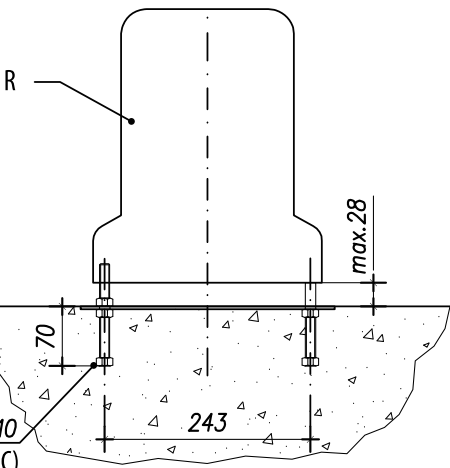

PLINTH POSITIONING DIAGRAM

FRONT VIEW

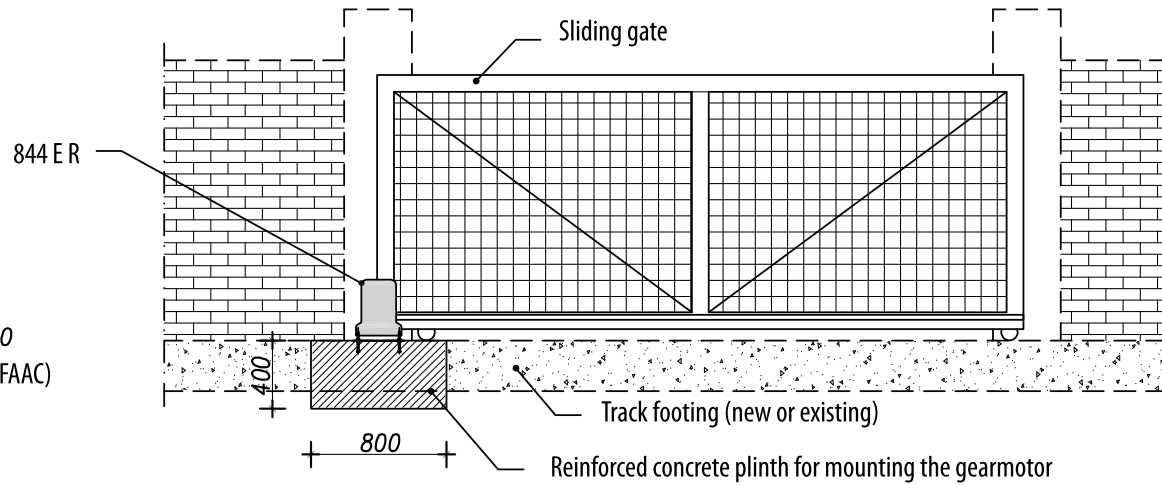

PLAN VIEW

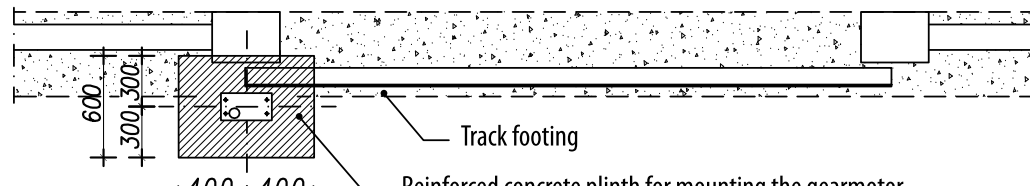

MATERIALS

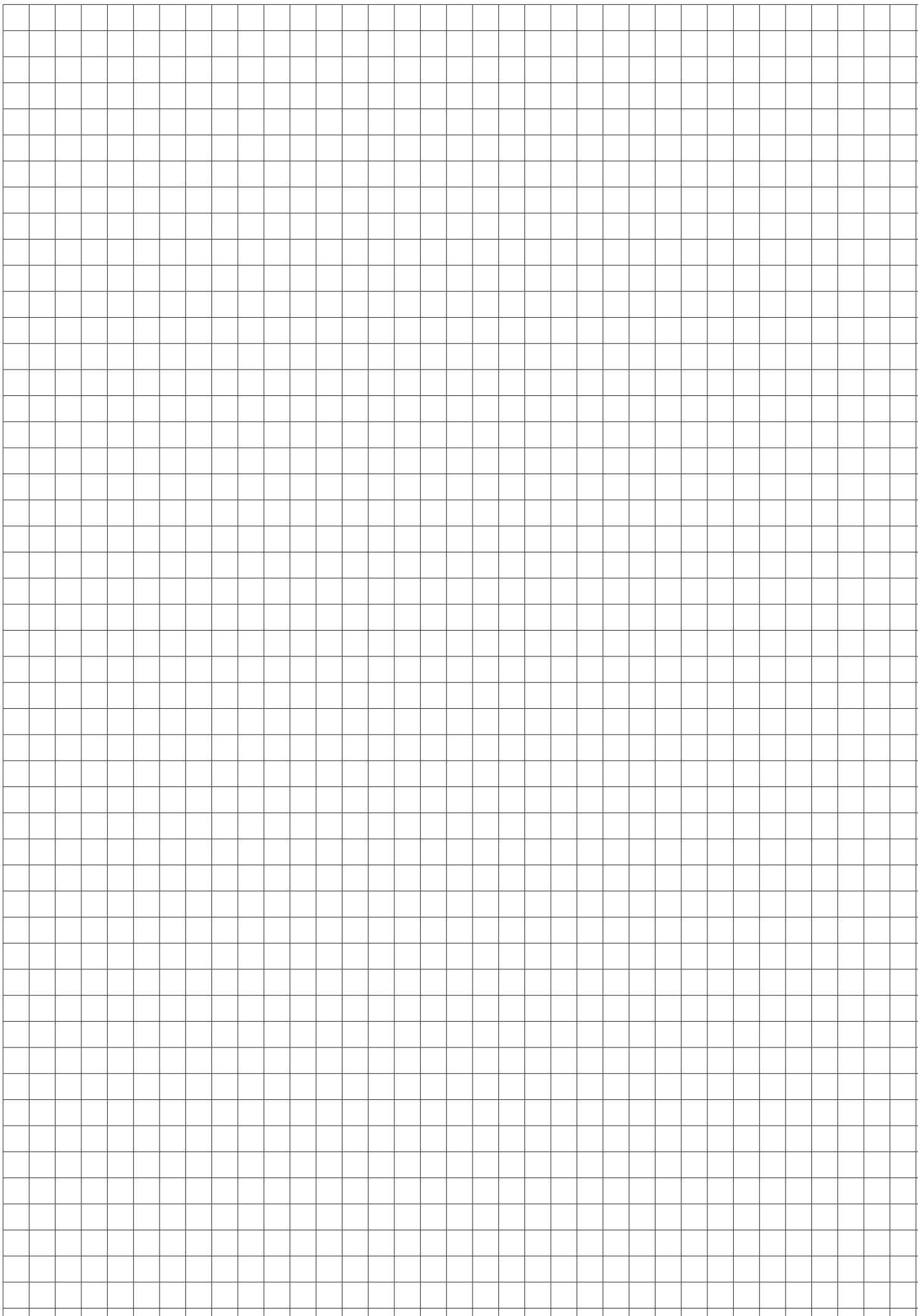

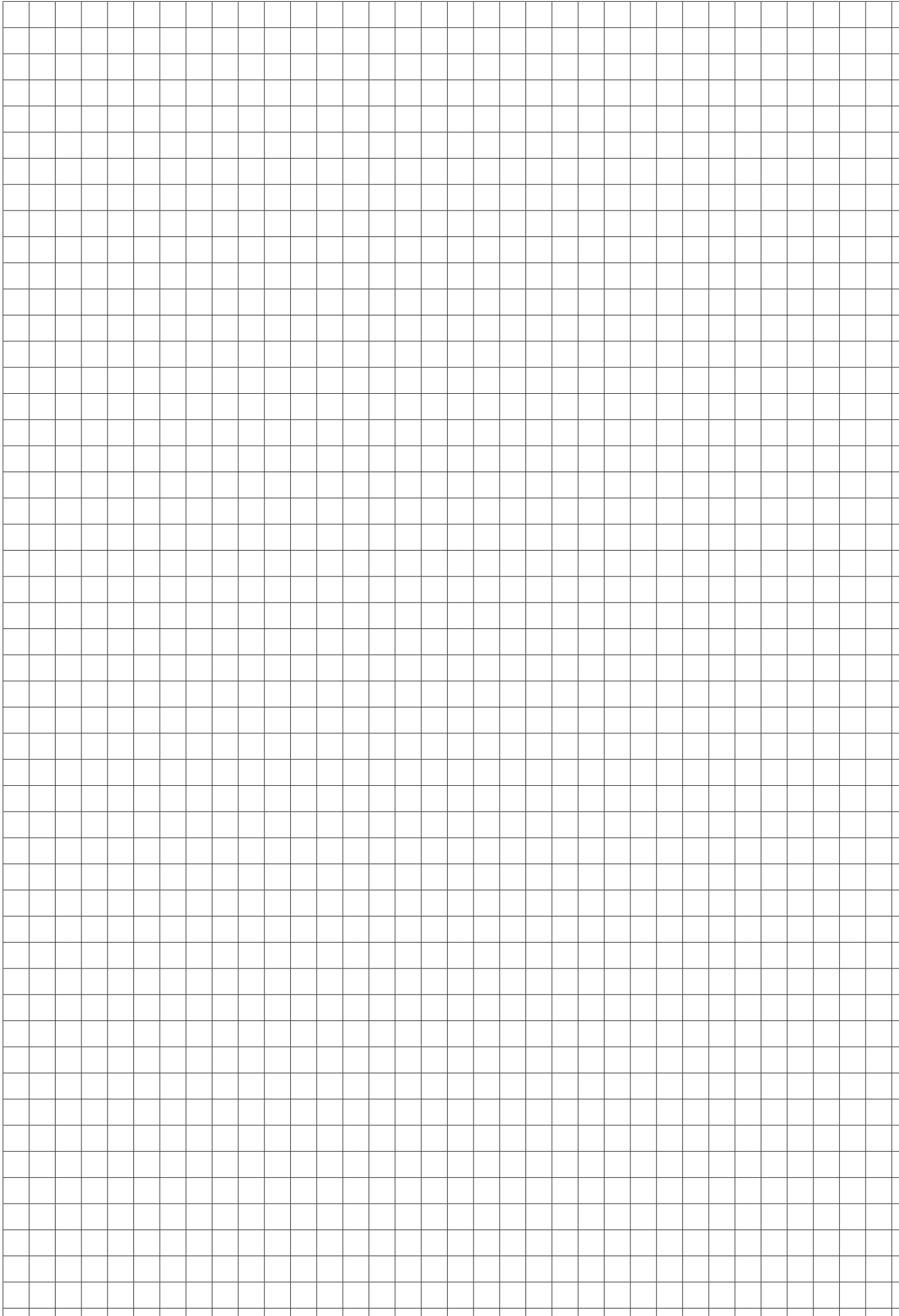

FAAC